



# PIPE EQUIPMENT SPECIALISTS COMPLETE MACHINES BROCHURE

## PIPE BEVELLING MACHINES



## PIPE COLD CUTTING AND BEVELLING MACHINES



## PLATE BEVELLERS





## SPECIALIZED FABRICATION EQUIPMENT GROUP

### Introduction to S.F.E. Group

S.F.E. Group was founded in 2019 after the merger of three world leading OEM's in the field of pipe fabrication tooling and machinery: B&B Pipe and Industrial Tools LLC (USA), Mathey Dearman Inc. (USA) and TAG Pipe Equipment Specialist Ltd. (UK). S.F.E. Group offers a wide range of products and is continuously exploring new product design and further development as well as add on acquisitions to enhance its portfolio and to fulfil increasing industries' demands.

With offices and warehousing on 4 continents, 100 employees and more than 250 partnerships and distributors worldwide, S.F.E. Group prides itself in consistently offering the highest standard of both product quality and service to all our customers. We look forward to welcoming you into our global network as a S.F.E. Group partner, distributor or end user customer and remain at your disposal at any time.



 USA Head Office - Houston



 International Head Office - UK



PIPE EQUIPMENT SPECIALISTS

**TAG Pipe Equipment Specialists Ltd.** based in the United Kingdom are innovators and manufactures of a comprehensive range of pipe cold cutting and bevelling machines. TAG has over 35 employees and have established multiple locations across 4 continents.

#### PIPE BEVELLING MACHINES



TAG manufacture a large range of I/D locking portable end PREP machines ranging from ½" to 42". TAG bevelling machines can produce all types of weld preparations required on any kind of metals from standard carbon steel to tough material such as super duplex and inconel.

#### PIPE CUTTING MACHINES



TAG also manufacture a diverse range of small, medium and large diameter pipe cutting and bevelling machines covering from 1" to 120" pipe, with designs available for both workshop and job site applications.

[www.TAG-PIPE.com](http://www.TAG-PIPE.com)



**B&B Pipe and Industrial Tools, LLC** is based in Houston Texas and are recognized as an aggressive and growing brand in the pipe and heavy industrial construction markets. B&B has approximately 40 employees and sells its products internationally on every continent.

#### PIPE JACKS AND STANDS



Over the past several years, B&B has led the market in the pipe jack and stand product category offering more models and innovative variations than any other manufacturer. With thousands of products sold every year, B&B is one of the recognized leaders in this category.

#### MATERIAL HANDLING EQUIPMENT



B&B's line of material handling carts and buggies compliments the jacks and stands product category from a distribution and supply chain perspective. This line also allows further expansion into new product markets.

[www.BBPIPETOOLS.com](http://www.BBPIPETOOLS.com)



**Mathey Dearman** based in Tulsa, Oklahoma is an 80-year-old company with 45 employees. Mathey Dearman is known as the pioneer of Mathey saddle type pipe cutters and bevellers, as well as Dearman type alignment and reforming clamps.

#### PIPE FLAME CUTTING AND BEVELLING



Mathey manufactures multiple flame and plasma pipe cutters and bevellers and are recognized as the leader in this product category. These machines are used across multiple fabrication projects, most commonly found in the energy construction markets.

#### PIPE ALIGNMENT CLAMPS



With the invention of the Dearman clamp taking lead, additional pipe alignment and reforming clamps are now offered exhibiting the most complete line in the industry.

#### PIPE RIGGING EQUIPMENT



A new line of pipe rigging products will be offered under the Mathey brand in 2020. Pipe slings and cradles, pipe launchers and rigging rollers add focus on a complimentary pipeline product category to Mathey saddle machines and cage clamps.

[www.MATHEY.com](http://www.MATHEY.com)



We are also excited to launch a new brand called **Pipe Purging Masters (PPM)**. This brand will offer a comprehensive and innovative range of pipe purging equipment.

**PIPE PURGING SYSTEMS**

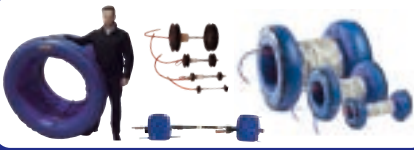

PPM's range of purge systems greatly reduce the purging time and give significant gas savings while producing a top quality weld.

**PURGE OXYGEN MONITORS**



PPM also offer a full range of weld purge monitoring systems to accurately measure the level of oxygen within the weld chamber for high quality purity welding.

**PIPE STOPPERS**

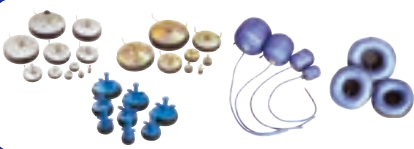

In addition to our purging systems and purge monitors PPM also offer an extensive range of pipe stoppers from inflatable stoppers available in all shapes, sizes and materials, as well as expanding stoppers available in nylon, steel and aluminium.

[www.PURGEMASTERS.com](http://www.PURGEMASTERS.com)

**FIT-UP PRO**

By Mathey Dearman

We are also excited to launch a new brand called **FIT-UP PRO** By Mathey Dearman. This brand will offer a comprehensive and innovative range of layout and fit up tools.

**LAYOUT TOOLS**



Fit-Up Pro offers several tools specific to pipe layout. A new pocket level and fitters torpedo level are made from aircraft aluminum balancing light weight and durability. A newly designed pipe centering tool adds magnets for hands free use and comes with a right angle square and handy ruler markings, and our line of radius markers is great for laying out a radius or circles up to 100 inches. Check out our complete line of layout tools from Fit-Up Pro.

**FIT-UP PRO**

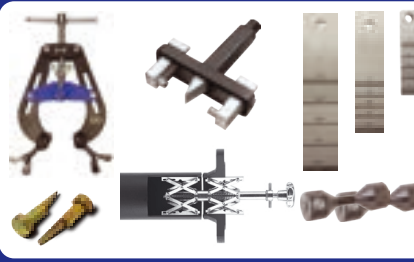

Our spider clamps are great for flange fit up and we also offer other types of alignment pipe clamps that save time and increase productivity. Two hole pins, flange alignment bolts and stepped wedges are also time savers that compliment this line, along with various squares and protractors. We even offer two types of flange spreaders, manual and hydraulic that assist in safe maintenance and preparation for re-fit of flanges. Contact us for information on our new brand, Fit-Up Pro.

[www.MATHEY.com](http://www.MATHEY.com)



### Customer Service

We work extremely hard supporting and training our team of employees and network of partners and distributors to ensure that from The S.F.E. Group you always receive the:

- Fastest response times
- Quickest delivery times
- Most knowledgeable and accurate advice
- Committed after sales support



### Level of Stock

S.F.E. Group carry an unrivalled stock level, meaning no matter how large your order we expect to offer you the fastest delivery time available worldwide.

### Price

You will find our pricing to be very competitive. Give us an opportunity to quote your next project and we are confident you will be pleased! For your convenience we offer our products in the three major currencies: US Dollar, Euro and GB Pound.



### Research and Development

Technology is always improving. At S.F.E. Group we firmly intend to move with the times and to be the innovators in our industry with a dedicated team of designers and technicians devoted to improving our existing products as well as innovating the next generation of pipework machinery and tools. All user feedback is passed onto the R&D department to ensure our machines are developed to meet all end user needs. We often hold meetings with customers to ensure the package provided meets all their requirements including custom made machines.



### Production, Assembly and Quality Control

With manufacturing partners in UK, USA, Belgium and Italy, S.F.E. Group are proud to offer the highest quality of components manufactured wholly in Europe/USA. All our machines are assembled in our UK/USA facility and undergo vigorous testing and quality control, which is backed by our products being CE Certified, having Certificates of Conformity, UK/USA Certificates of Origin and our company being ISO9001 accredited.



### Demonstrations, Training and Exhibitions

We love to show off our products unrivalled performance and are always happy to carry out demonstrations either in our showroom facility in the UK/USA or at your site. In addition we understand the importance of the correct operation of our machinery and tools so also offer training packages again either in our UK/USA training facility or at your site ensuring safe, efficient and accurate operation. We also participate in all the relevant world wide exhibitions. We also have extremely detailed user manuals and instructional videos.



### Rental Division

The S.F.E. Group operates a full, worldwide hire and rental service in cooperation with and supported by its selected and specialized rental partners. S.F.E. Group continuously keeps expanding its rental activities, rental fleet and network and prides itself keeping its renting equipment up to date in order to provide the best possible quality, performance and reliability. S.F.E. Group invites you to share your rental enquiry and will tailor the matching solution to your needs.

**Please contact your local S.F.E. Group branch for all enquiries.  
Details of which can be found on the back cover of this publication.**

# INDEX

<b>Introduction to S.F.E. Group</b> .....	<b>2</b>
TAG Pipe Equipment Specialists .....	2
B&B Pipe and Industrial Tools .....	3
Mathey Dearman .....	3
PPM - Pipe Purge Masters.....	4
Fit-up Pro by Mathey Dearman.....	4
<b>TAG PREP Pipe Bevelling Machines</b> .....	<b>7</b>
TAG PREP 2 Pipe Bevelling ½" to 1½" .....	7
TAG PREP 3 Pipe Bevelling 1" to 3" .....	11
TAG PREP 4 Pipe Bevelling 1" to 4" .....	15
TAG PREP 8 Pipe Bevelling 2" to 8" .....	19
TAG PREP 16 Pipe Bevelling 3" to 16" .....	23
TAG PREP 24 Pipe Bevelling 7" to 24" .....	27
TAG PREP 16 and PREP 24 Elbow / Fittings .....	31
TAG PANEL PREP Machines .....	32
<b>TAG Pipe Cold Cutting Machines</b> .....	<b>33</b>
TAG Split Frame Clamshell Cold Cutting and Bevelling Machines 1" to 48" .....	33
TAG Split Frame Clamshell Cold Cutting and Bevelling Machines 48" to 120" .....	43
TAG E-Z FAB Pipe Cutting and Bevelling Machines 1" to 24" .....	45
TAG E-Z Pipe Saw 1" to 12" .....	50
<b>TAG Plate Bevelling Machines</b> .....	<b>51</b>
TAG PMM155 .....	52
TAG PMM200 .....	53
TAG PMM200SS .....	54



**SPECIALIZED FABRICATION EQUIPMENT**  
GROUP

*Our group policy is one of continuous improvement.  
Products and data tables are subject to change or vary from those illustrated.*

## OUR BRANDS





PIPE EQUIPMENT SPECIALISTS

# PREP 2 PIPE BEVELLING $\frac{1}{2}$ " to $1\frac{1}{2}$ "

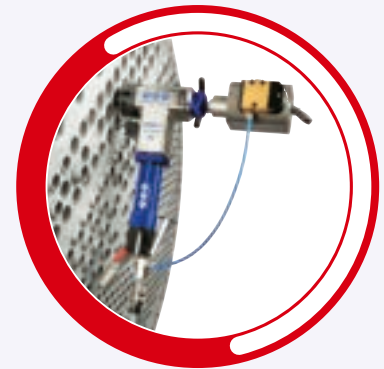

SCAN QR CODE  
TO WATCH VIDEO



**RANGE: 23 - 42mm i/d / 0.9 - 1.5" i/d**  
**(optional from 12.5mm i/d / 0.5" i/d)**

- **Functions:** External beveling / internal beveling / elbow and fittings beveling / facing, counter-boring / weld removal / J-prepping and facing of tube plate
- **Materials:** Any kind of steel and exotic alloy
- **Power:** Pneumatic, electric or battery (110v or 220v)

The smallest in our range of i/d locking, direct in-line feed end prep machines. The PREP 2 is small, light weight, yet powerful, in electric, battery (110v or 220v) or pneumatic drive form. A 4-jaw tool holder (chuck) allows use of up to 4 form tools to enable weld preparation of thin wall tube, or heavy wall pipe. Simultaneous external and internal beveling and facing of tubes is simple, ideal for accurate repetitive work. It's size, power, and functionality, make it extremely popular in high volume heat exchanger work, tube facing, weld removal, and J-prepping of the tube plate. Also used extensively on power station shutdowns for boiler panel bevels.



**FEATURES AND ADVANTAGES**

The PREP 2 is torque reactive. This means that the pipe or tube does not have to be fixed to be bevelled, making it particularly useful on-site, in maintenance and repair situations. This is due to the design and strength of the thru shaft system that locks to the bore of the pipe.

The jaw system itself consists of 3 equilateral positioned machined jaw segments, retained and locked on an inner, 'grooved' expansion shaft. These grooves keep the jaws held securely in position, unlike other systems that use a metal or rubber bands for jaw retention. As the expansion nut is tightened, the jaws expand, locking tightly, and square to the bore of the pipe.

The machine body is CNC machined out of solid aluminium and nickel plated, this ensures strength and we can keep precise tolerances on all components, resulting in a stable heavy duty machine that does not move under load, we also ensure all components are treated utilising the latest technologies to ensure durability.

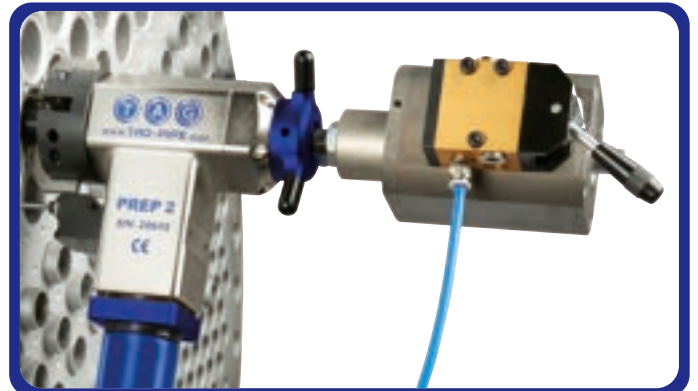

 **MADE IN UK** 

# POWER OPTIONS:

**PNEUMATIC**



**PART NO. TP2P**

**ELECTRIC**



**PART NO. TP2E110 / TP2E220**

**BATTERY**



**PART NO. TP2B110 / TP2B220**

**COMPLETE LEVER**



**PART NO. TP2PALL**

# ACCESSORIES AND OPTIONS:

**REDUCED SHAFT**

12.5 - 23mm i/d  
0.5 - 0.9" i/d



**PART NO. TP2RSK**

**ELBOW / FITTINGS SHAFT**



26 - 51mm i/d  
1 - 2" i/d

**PART NO. TP2ESK**

**AUTO LOCK**

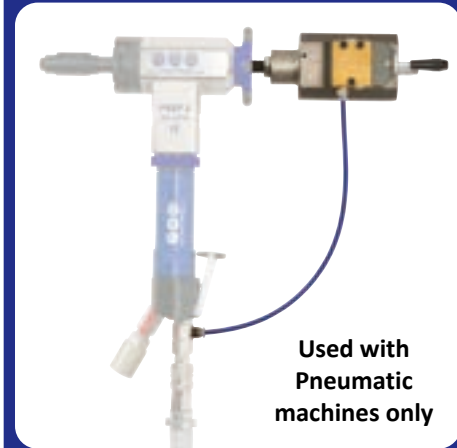

Used with  
Pneumatic  
machines only

**PART NO. TP2ALD**

**RATCHET HANDLES**



**PART NO. TP2RHK**

**FEED STOPPER**



**PART NO. TP2FSK**

**MILLING HEADS**



**PART NO. CTBHSF\*\*\***

## PREP 2 TECHNICAL FEATURES

DESCRIPTION	MEASUREMENT	PNEUMATIC	ELECTRIC	BATTERY
Part Number	n/a	TP2P / TP2PALL	TP2E110 / TP2E220	TP2B110 / TP2B220
Locking tube range	mm (i/d)	23 - 42 Optional from 12.5	23 - 42 Optional from 12.5	23 - 42 Optional from 12.5
Locking tube range	inch (i/d)	0.9 - 1.5" Optional from 0.5"	0.9 - 1.5" Optional from 0.5"	0.9 - 1.5" Optional from 0.5"
Idle speed	rpm	5 - 215	5 - 250	80 / 120 / 160
Torque	N m	56	50	60
Length of axial feed	mm	24	24	24
Max operating temperature	°C	55	55	55
Max acoustic radiation	dB	75	75	75
Pneumatic motor power	hp	0.7	n/a	n/a
Air consumption	cfm / l/min.	28 / 800	n/a	n/a
Air working pressure	psi / bar	90 / 6.5	n/a	n/a
Air hose connection	inches	½"	n/a	n/a
Electric motor power	watt	n/a	720	800
Voltage	volt	n/a	110 or 220	Charger 110 or 220
Frequency	Hz	n/a	50 / 60	Charger 50 / 60
Unit weight	kg / lbs	4.8 / 10.6	5.5 / 12	5.7 / 12.5
Packing dimensions	mm	545 x 400 x 120	545 x 400 x 120	560 x 570 x 120
Packing weight	kg / lbs	13.5 / 30	14.5 / 32	15.5 / 34

*Our group policy is one of continuous improvement. Products and data tables are subject to change or vary from those illustrated.*

- All units are supplied complete with all gripping segments to cover the full range of the machine. Service tools, drawings, instruction manual and warranty certificate are also supplied as standard.
- Each machine is supplied with a protective custom built metal box.
- Pneumatic machine must be used with filter lubricator and oil - use without will void warranty.



### DIMENSIONS



DIM	PNEUMATIC	ELECTRIC	BATTERY
A	400mm	430mm	470mm
B	316mm	316mm	316mm
∅C	106mm	106mm	106mm
∅D	67mm	67mm	67mm
E	54mm	72mm	72mm

### EXAMPLES OF COMMON CUTTING TOOLS

#### FORMED TOOLS

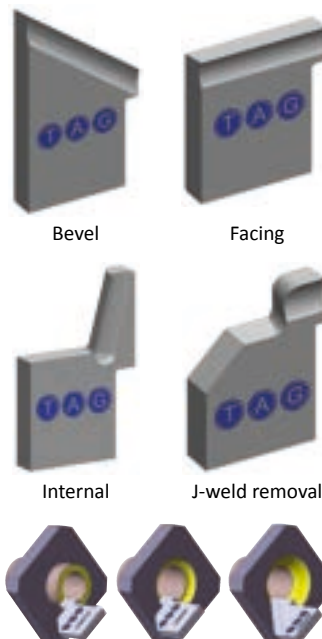

#### HOLDER / INSERT

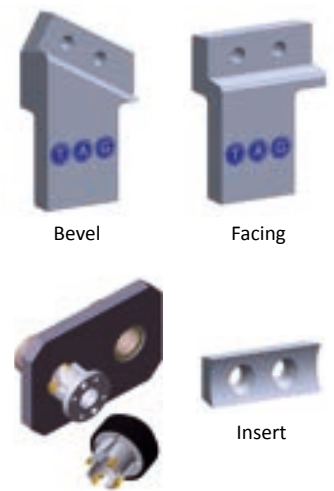

All shapes, sizes and angles available



**PIPE EQUIPMENT SPECIALISTS**

# PREP 3 PIPE BEVELLING 1" to 3"

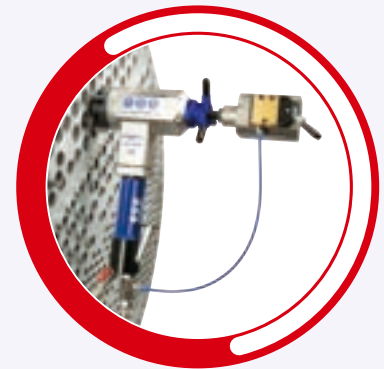

**SCAN QR CODE  
TO WATCH VIDEO**



**RANGE: 28 - 76mm i/d / 1 - 3" i/d**  
**(optional from 20mm i/d / 0.8" i/d)**

- **Functions:** External beveling / internal beveling / elbow and fittings beveling / facing / counter-boring / weld removal / J-prepping and facing of tube plate
- **Materials:** Any kind of steel and exotic alloy
- **Power:** Pneumatic, electric or battery (110v or 220v)

The PREP 3 is a popular i/d locking, in-line feed end prep machines. The PREP 3's power to weight ratio, in electric, battery (110v or 220v), or pneumatic drive form is unrivalled. A 4-jaw tool holder (chuck) allows use of up to 4 insert or form tools to enable beveling of heavy wall pipe and tube. Simultaneous external, internal and facing of tubes can be performed with ease for accurate repetitive work. Its size, power, and functionality, makes it extremely popular in high volume boiler repair and maintenance work, tube facing, weld removal, and J-prepping of the tube plates and panels.



**FEATURES AND ADVANTAGES**

The PREP 3 is torque reactive. This means that the pipe or tube does not have to be fixed to be bevelled, making it particularly useful on-site, in maintenance and repair situations. This is due to the design and strength of the thru shaft system that locks to the bore of the pipe.

The jaw system itself consists of 3 equilateral positioned machined jaw segments, retained and locked on an inner, 'grooved' expansion shaft.

These grooves keep the jaws held securely in position, unlike other systems that use a metal or rubber bands for jaw retention.

As the expansion nut is tightened, the jaws expand, locking tightly, and square to the bore of the pipe.



## POWER OPTIONS:

### PNEUMATIC



PART NO. TP3P

### ELECTRIC



PART NO. TP3E110 / TP3E220

### BATTERY



PART NO. TP3B110 / TP3E220

## ACCESSORIES AND OPTIONS:

### REDUCED SHAFT

20 - 30mm i/d  
0.8 - 1.2" i/d



PART NO. TP3RSKV2

### ELBOW / FITTINGS SHAFT



38 - 79mm i/d  
1.5 - 3" i/d

PART NO. TP3ESKV2

### AUTO LOCK

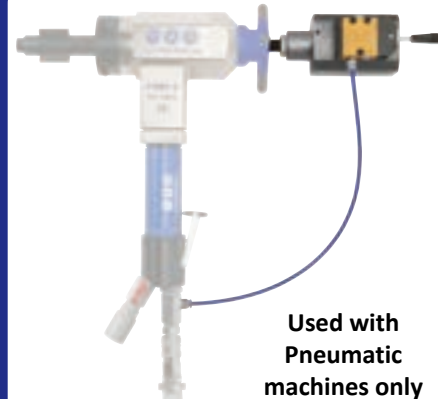

Used with  
Pneumatic  
machines only

PART NO. TP3ALD

### RATCHET HANDLES



PART NO. TP3RHKV2

### FEED STOPPER



PART NO. TP3FSK

### MILLING HEADS



PART NO. CTMH\*\*\*BMR

## PREP 3 TECHNICAL FEATURES

DESCRIPTION	MEASUREMENT	PNEUMATIC	ELECTRIC	BATTERY
Part Number	n/a	TP3P	TP3E110 / TP3E220	TP3B110 / TP3B220
Locking tube range	mm (i/d)	28 - 76 Optional from 20	28 - 76 Optional from 20	28 - 76 Optional from 20
Locking tube range	inch (i/d)	1 - 3" Optional from 0.8"	1 - 3" Optional from 0.8"	1 - 3" Optional from 0.8"
Idle speed	rpm	5 - 120	5 - 82	23 / 37 / 50
Torque	N m	140	152	140
Length of axial feed	mm	40.5	40.5	40.5
Max operating temperature	°C	55	55	55
Max acoustic radiation	dB	75	75	75
Pneumatic motor power	hp	1.35	n/a	n/a
Air consumption	cfm / l/min.	36 / 1020	n/a	n/a
Air working pressure	psi / bar	90 / 6.5	n/a	n/a
Air hose connection	inches	½"	n/a	n/a
Electric motor power	watt	n/a	1300	800
Voltage	volt	n/a	110 or 220	Charger 110 or 220
Frequency	Hz	n/a	50 / 60	Charger 50 / 60
Unit weight	kg / lbs	8.9 / 19.5	9.9 / 22	10.4 / 23
Packing dimensions	mm	640 x 500 x 140	640 x 500 x 140	640 x 640 x 140
Packing weight	kg / lbs	23 / 51	24 / 53	25 / 55

*Our group policy is one of continuous improvement. Products and data tables are subject to change or vary from those illustrated.*

- All units are supplied complete with all gripping segments to cover the full range of the machine. Service tools, drawings, instruction manual and warranty certificate are also supplied as standard.
- Each machine is supplied with a protective custom built metal box.
- Pneumatic machine must be used with filter lubricator and oil - use without will void warranty.



### DIMENSIONS

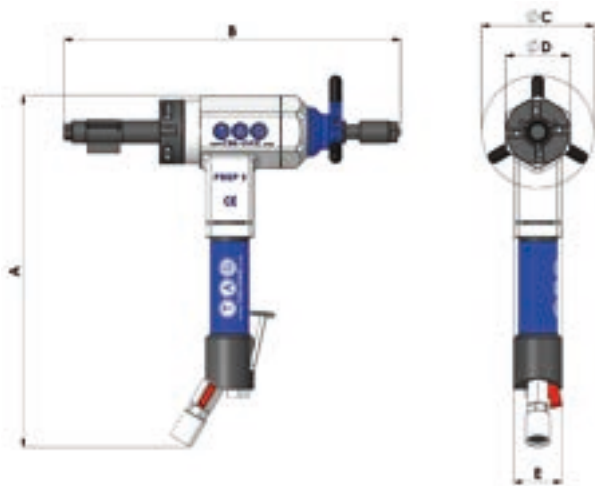

DIM	PNEUMATIC	ELECTRIC	BATTERY
A	435mm	500mm	530mm
B	402mm	402mm	402mm
∅C	140mm	140mm	140mm
∅D	80mm	80mm	80mm
E	60mm	90mm	90mm

### EXAMPLES OF COMMON CUTTING TOOLS

#### FORMED TOOLS

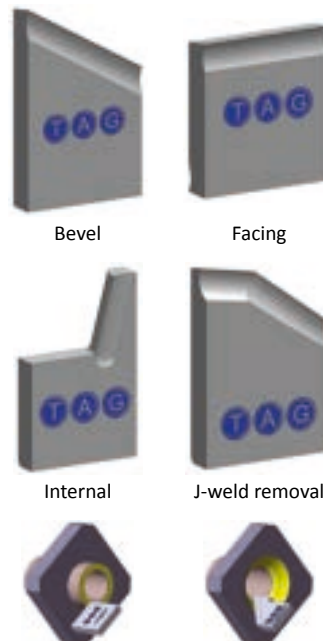

#### HOLDER / INSERT

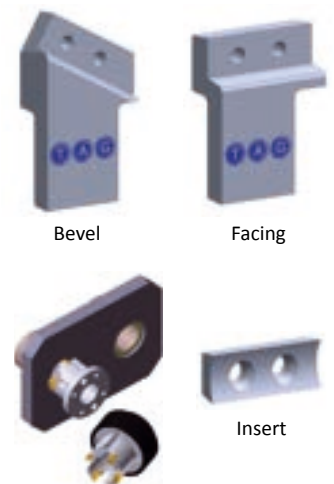

All shapes, sizes and angles available



**PIPE EQUIPMENT SPECIALISTS**

# PREP 4 PIPE BEVELLING 1" to 4"



**SCAN QR CODE  
TO WATCH VIDEO**



**TAG** **PREP 4**  
*Portable Pipe Beveling Machine*

**RANGE: 23 - 112mm i/d / 1 - 4" i/d**

- **Functions:** External beveling / internal beveling / elbow and fittings beveling / facing / counter-boring / weld removal / J-prepping and facing of tube plate
- **Materials:** Any kind of steel and exotic alloy
- **Power:** Pneumatic, electric or battery (110v or 220v)

The PREP 4 is one of our most popular i/d locking, in-line feed end prep machines. The PREP 4's power to weight ratio, in electric, battery (110v or 220v), or pneumatic drive form is unrivalled. A 4-jaw tool holder (chuck) allows use of up to 4 insert or form tools to enable beveling of heavy wall pipe and tube, simultaneous external, internal and facing of tubes can be performed with ease for accurate repetitive work. Its size, power, and functionality, makes it extremely popular in high volume boiler repair and maintenance work, tube facing, weld removal, and J-prepping of the tube plate.



**FEATURES AND ADVANTAGES**

The PREP 4 is torque reactive. This means that the pipe or tube does not have to be fixed to be bevelled, making it particularly useful on-site, in maintenance and repair situations. This is due to the design and strength of the thru shaft system that locks to the bore of the pipe.

The jaw system itself consists of 3 equilateral positioned machined jaw segments, retained and locked on an inner, 'grooved' expansion shaft.

These grooves keep the jaws held securely in position, unlike other systems that use a metal or rubber bands for jaw retention.

As the expansion nut is tightened, the jaws expand, locking tightly, and square to the bore of the pipe.

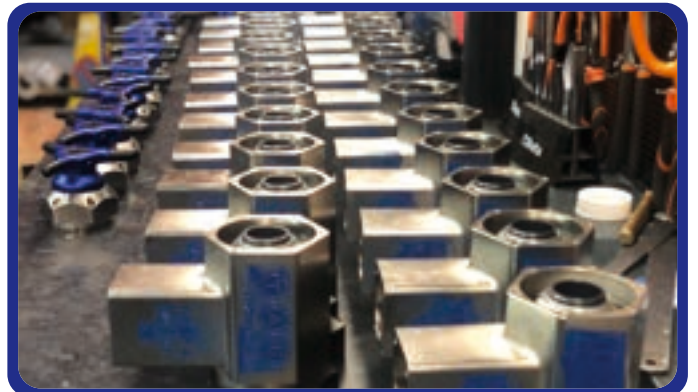

 **MADE IN UK** 

# POWER OPTIONS:

## PNEUMATIC



PART NO. TP4P

## ELECTRIC



PART NO. TP4E110 / TP4E220

## BATTERY



PART NO. TP4B110 / TP4B220

# ACCESSORIES AND OPTIONS:

## ELBOW / FITTINGS SHAFT

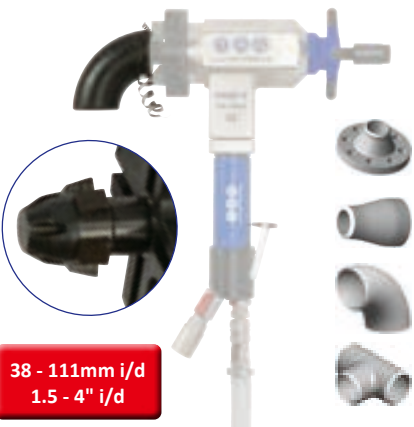

38 - 111mm i/d  
1.5 - 4" i/d

PART NO. TP4ESKV2

## AUTO LOCK

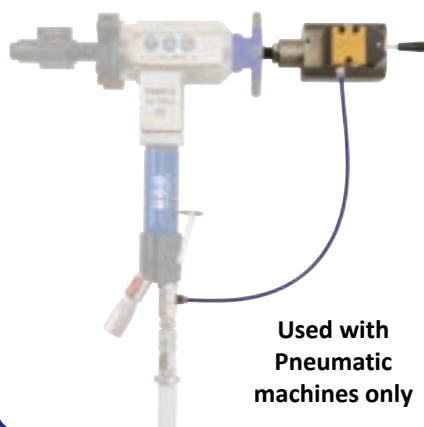

Used with  
Pneumatic  
machines only

PART NO. TP4ALD

## RATCHET HANDLES



PART NO. TP4RHKV2

## FILTER LUBRICATOR



PART NO. AFL1



## PREP 4 TECHNICAL FEATURES

DESCRIPTION	MEASUREMENT	PNEUMATIC	ELECTRIC	BATTERY
Part Number	n/a	TP4P	TP4E110 / TP4E220	TP4B110 / TP4B220
Locking tube range	mm (i/d)	23 - 112	23 - 112	23 - 112
Locking tube range	inch (i/d)	1 - 4"	1 - 4"	1 - 4"
Idle speed	rpm	5 - 100	5 - 82	23 / 37 / 50
Torque	N m	176	152	140
Length of axial feed	mm	40.5	40.5	40.5
Max operating temperature	°C	55	55	55
Max acoustic radiation	dB	75	75	75
Pneumatic motor power	hp	1.35	n/a	n/a
Air consumption	cfm / l/min.	36 / 1020	n/a	n/a
Air working pressure	psi / bar	90 / 6.5	n/a	n/a
Air hose connection	inches	½"	n/a	n/a
Electric motor power	watt	n/a	1300	800
Voltage	volt	n/a	110 or 220	Charger 110 or 220
Frequency	Hz	n/a	50 / 60	Charger 50 / 60
Unit weight	kg / lbs	9.4 / 20.7	10.4 / 23	11.1 / 24.5
Packing dimensions	mm	640 x 500 x 140	640 x 500 x 140	640 x 640 x 140
Packing weight	kg / lbs	28.5 / 63	29.5 / 65	30.5 / 67

*Our group policy is one of continuous improvement. Products and data tables are subject to change or vary from those illustrated.*

- All units are supplied complete with all gripping segments to cover the full range of the machine. Service tools, drawings, instruction manual and warranty certificate are also supplied as standard.
- Each machine is supplied with a protective custom built metal box.
- Pneumatic machine must be used with filter lubricator and oil - use without will void warranty.



### DIMENSIONS

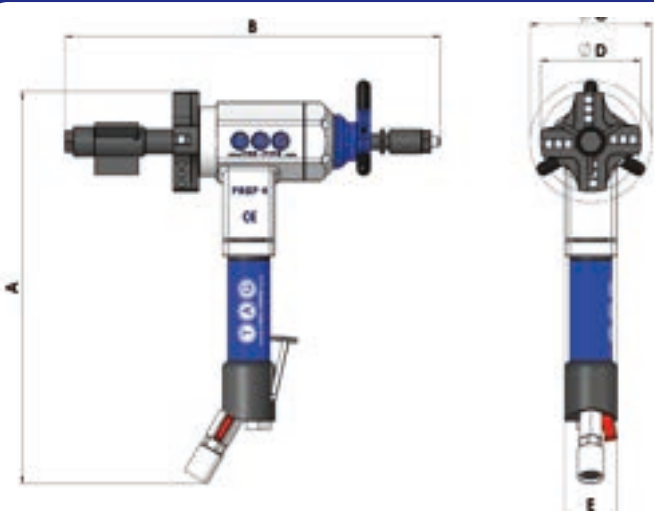

DIM	PNEUMATIC	ELECTRIC	BATTERY
A	455mm	510mm	540mm
B	434mm	434mm	434mm
∅C	140mm	140mm	140mm
∅D	115mm	115mm	115mm
E	60mm	90mm	90mm

### EXAMPLES OF COMMON CUTTING TOOLS

#### FORMED TOOLS

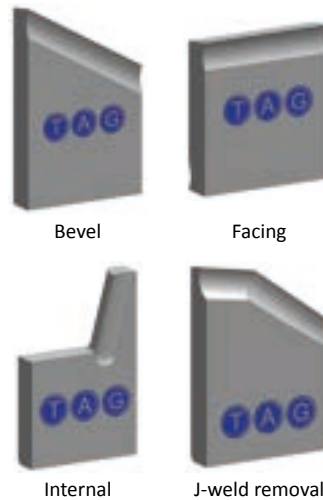

#### HOLDER / INSERT

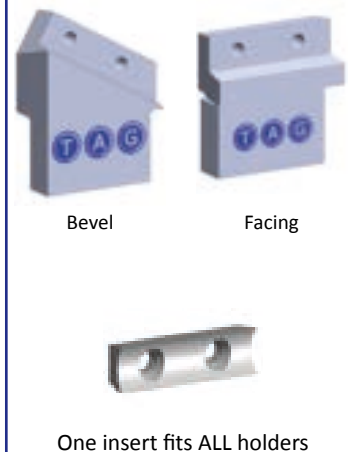

***All shapes, sizes and angles available***



PIPE EQUIPMENT SPECIALISTS

# PREP 8 PIPE BEVELLING 2" to 8"



SCAN QR CODE  
TO WATCH VIDEO





# PREP 8

Portable Pipe Beveling Machine

**RANGE: 50 - 211mm i/d / 2 - 8" i/d**

- **Functions:** External beveling / internal beveling / elbow and fittings beveling / facing / counter-boring / weld removal / J-prepping / compound bevels
- **Materials:** Any kind of steel and exotic alloy
- **Power:** Pneumatic or electric (110v or 220v)

One of our most powerful and popular i/d locking, in-line feed end prep machines. This is mainly due to its impressive 2 - 8" working range and unrivalled power. The PREP 8 is a portable, one man operation machine, its power to weight ratio, and offset 4-jaw tool holder (chuck) allows use of up to 4 insert or form tools to enables simultaneous external, internal beveling of even the heaviest wall pipe. The PREP 8 is a real workhorse. It's size, power, and functionality, make it extremely popular in high volume heavy duty beveling applications, on site, or in the workshop.



## FEATURES AND ADVANTAGES

The PREP 8 is torque reactive. This means that the pipe or tube does not have to be fixed to be bevelled, making it particularly useful on-site, in maintenance and repair situations. This is due to the design and strength of the thru shaft system that locks to the bore of the pipe.

The jaw system itself consists of 3 equilateral positioned machined jaw segments, retained and locked on an inner, 'grooved' expansion shaft.

These grooves keep the jaws held securely in position, unlike other systems that use a metal or rubber bands for jaw retention.

As the expansion nut is tightened, the jaws expand, locking tightly, and square to the bore of the pipe.



**MADE IN UK**



# POWER OPTIONS:

## PNEUMATIC



PART NO. TP8P

## ELECTRIC



PART NO. TP8E110 / TP8E220

# ACCESSORIES AND OPTIONS:

## ELBOW / FITTINGS SHAFT



56 - 215mm i/d  
2 - 8" i/d

PART NO. TP8ESK

## AUTO LOCK

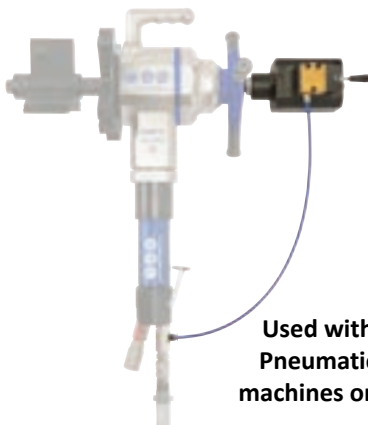

Used with  
Pneumatic  
machines only

PART NO. TP8ALD

## RATCHET HANDLES



PART NO. TP8RHK

## FILTER LUBRICATOR



PART NO. AFL1



## PREP 8 TECHNICAL FEATURES

DESCRIPTION	MEASUREMENT	PNEUMATIC	ELECTRIC
Part Number	n/a	TP8P	TP8E110 / TP8E220
Locking tube range	mm (i/d)	50 - 211	50 - 211
Locking tube range	inch (i/d)	2 - 8"	2 - 8"
Idle speed	rpm	5 - 52	5 - 34
Torque	N m	265	280
Length of axial feed	mm	40	40
Max operating temperature	°C	55	55
Max acoustic radiation	dB	75	75
Pneumatic motor power	hp	1.85	n/a
Air consumption	cfm / l/min.	50 / 1400	n/a
Air working pressure	psi / bar	90 / 6.5	n/a
Air hose connection	inches	¾"	n/a
Electric motor power	watt	n/a	1900
Voltage	volt	n/a	110 or 220
Frequency	Hz	n/a	50 / 60
Unit weight	kg / lbs	25 / 55	26 / 57
Packing dimensions	mm	830 x 780 x 250	830 x 610 x 250
Packing weight	kg / lbs	55 / 121	54 / 119

*Our group policy is one of continuous improvement. Products and data tables are subject to change or vary from those illustrated.*

- All units are supplied complete with all gripping segments to cover the full range of the machine. Service tools, drawings, instruction manual and warranty certificate are also supplied as standard.
- Each machine is supplied with a protective custom built metal box.
- Pneumatic machine must be used with filter lubricator and oil - use without will void warranty.



### DIMENSIONS

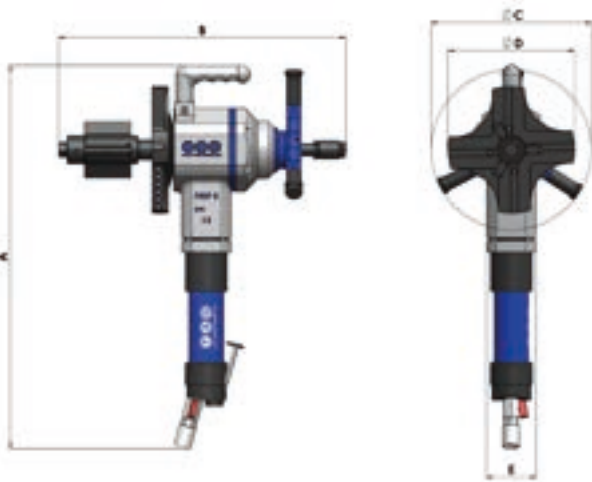

DIM	PNEUMATIC	ELECTRIC
A	670mm	700mm
B	520mm	520mm
∅C	278mm	278mm
∅D	220mm	220mm
E	86mm	90mm

### EXAMPLES OF COMMON CUTTING TOOLS

#### FORMED TOOLS

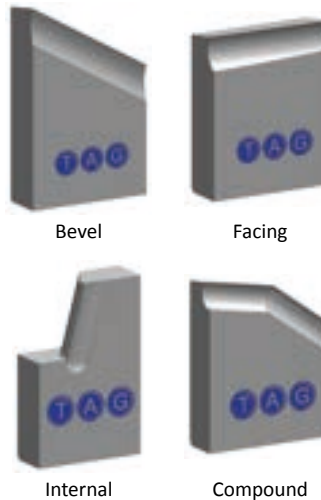

#### HOLDER / INSERT

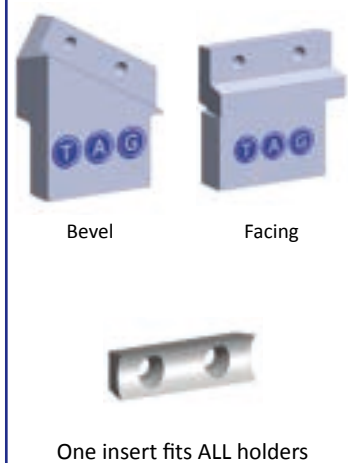

***All shapes, sizes and angles available***



**PIPE EQUIPMENT SPECIALISTS**

# PREP 16 PIPE BEVELLING 3" to 16"



SCAN QR CODE  
TO WATCH VIDEO

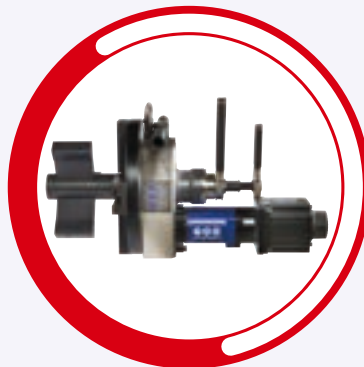

**RANGE: 72 - 400mm i/d / 2.8 - 15.74" i/d**

- **Functions:** External beveling  
Internal beveling  
Facing  
Counter-boring  
Weld removal  
J-prepping  
Compound bevels
- **Materials:** Any kind of steel and exotic alloy
- **Power:** Servo electric, pneumatic or hydraulic



**FEATURES AND ADVANTAGES**

The PREP 16 is the first in TAG's new range of a heavy duty mid-large diameter beveling machines.

Offering ratcheted i/d jaw locking as well as ratchet bevel feed control for effortless heavy wall preps, offered in extremely powerful user friendly servo electric or pneumatic any bevel geometry can be performed within the impressive 3" - 16" range.

J-preps, counter boring, and facing can all be performed, simultaneously, using the correct tooling fitted in (up to) 4 heavy duty hardened multi-position tool holders. Due to its light weight, yet unrivalled power, the PREP 16 is ideal for on-site, off shore, nuclear, and other applications where precision welds are required at an incredible value.

The PREP 16, and its bigger brother the PREP 24, utilise ratchet feed and locking. This allows effortless set-up, and enables the operator to deliver consistent feed with minimal effort.



 **MADE IN UK** 

**POWER OPTIONS:**

**SERVO ELECTRIC**

**RECOMMENDED**

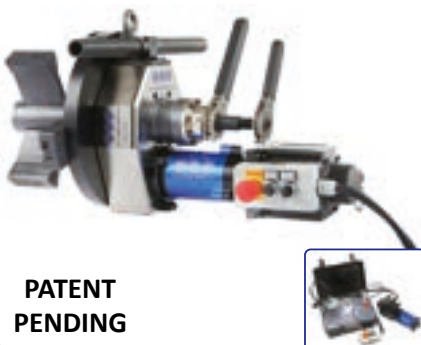

**PATENT  
PENDING**



**PART NO. TP16SE110 / TP16SE220**

**PNEUMATIC**



**PART NO. TP16P**

**HYDRAULIC**



**PART NO. TP16H**

# FEATURES:

## SELF-CENTERING

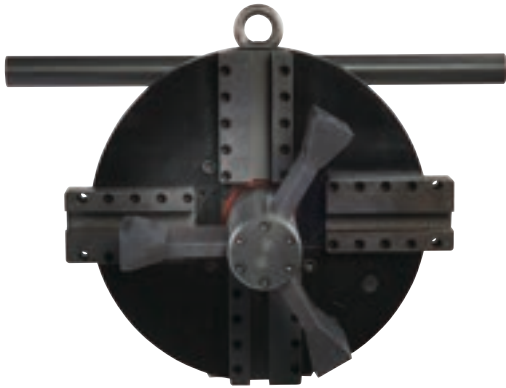

Self-centering 70mm (2.75") one piece locking shaft with built in jaws, eliminates the issue of broken or loosening retaining springs and o-rings.

## UNRIVALLED POWER AND STABILITY



TAG innovative bearing/crown and pinion design combined with our large shaft, delivers unrivalled power and stability.

## SERVO ELECTRIC



**PATENT  
PENDING**

SERVO ELECTRIC control box makes the strongest portable pipe beveling machine available on the market.

## LIFTING HANDLES



To enable ease of set up, the machine is equipped with lifting handles and removable extensions so the machine can be easily installed, and removed from the pipe.

## RATCHET FEED AND LOCKING



The PREP 16 has unrivalled power and stability, utilising a ratchet system for both jaw locking, and bevel feed.

## SIX POINT LOCKING



Innovative wide locking jaws offer 6 point locking from 3 jaws giving superior clamping force for chatter free end preps.

## PREP 16 TECHNICAL FEATURES

DESCRIPTION	MEASUREMENT	PNEUMATIC	SERVO ELECTRIC	HYDRAULIC
Part Number	n/a	TP16P	TP16SE110 / TP16SE220	TP16H
Locking tube range	mm / inch (i/d)	72 - 400 / 2.8 - 15.74"	72 - 400 / 2.8 - 15.74"	72 - 400 / 2.8 - 15.74"
Working range	mm / inch (o/d)	72 - 406 / 3 - 16"	72 - 406 / 3 - 16"	72 - 406 / 3 - 16"
Idle speed	rpm	5 - 18	1 - 18	1 - 26
Length of axial feed	mm / inch	50 / 2	50 / 2	50 / 2
Max operating temperature	°C	55	60	60
Max acoustic radiation	dB	75	45	55
Pneumatic Motor Power	hp	3.5	n/a	5.4
Air Consuming Flux	cfm / l/min.	90 / 2500	n/a	n/a
Air working pressure	psi / bar	90 / 6.5	n/a	n/a
Air Hose Connection	inches	¾"	n/a	n/a
Servo Electric Motor Power	kw	n/a	1.5	n/a
Voltage	volt	n/a	110 or 220	Refer to Hydraulic Power Pack
Frequency	Hz	n/a	50 / 60	Refer to Hydraulic Power Pack
Remote Control	Yes / No	No	Yes	Yes
Forward / Reverse	Yes / No	No	Yes	Yes
Unit weight	kg / lbs	43 / 95	44 / 97	41 / 90
Packing dimensions L x W x H	mm	860 x 570 x 530	860 x 570 x 530	860 x 570 x 530
Packing weight	kg / lbs	128 / 282	140 / 305	125 / 275

*Our group policy is one of continuous improvement. Products and data tables are subject to change or vary from those illustrated.*

- All units are supplied complete with all locking jaws to cover the full range of the machine. Service tools, drawings, instruction manual and warranty certificate are also supplied as standard.
- Each machine is supplied with a protective custom built box.
- Pneumatic machine must be used with filter lubricator and oil - use without will void warranty.



### DIMENSIONS

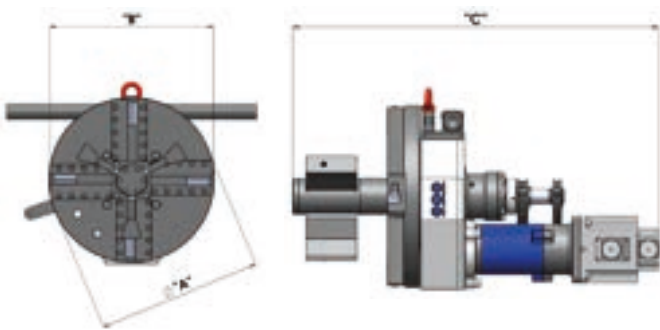

DIMENSIONS		PNEUMATIC	SERVO ELECTRIC	HYDRAULIC
∅A	mm	323	323	323
B	mm	407	407	407
C	mm	750	630	530

### EXAMPLES OF COMMON CUTTING TOOLS

#### FORMED TOOLS

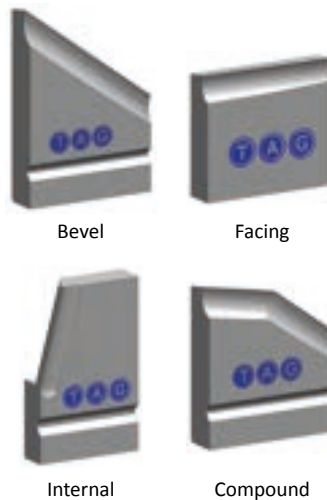

#### HOLDER / INSERT (Recommended)

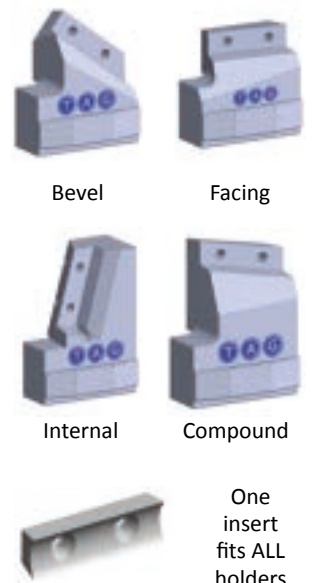

All shapes, sizes and angles available



PIPE EQUIPMENT SPECIALISTS

# PREP 24 PIPE BEVELLING 7" to 24"



SCAN QR CODE  
TO WATCH VIDEO



**RANGE: 175 - 600mm i/d / 6.9 - 23.6" i/d**

- **Functions:** External beveling  
Internal beveling  
Facing  
Counter-boring  
Weld removal  
J-prepping  
Compound bevels
- **Materials:** Any kind of steel and exotic alloy
- **Power:** Servo electric, pneumatic or hydraulic



**FEATURES AND ADVANTAGES**

The PREP 24 is the largest in TAG's new range of a heavy duty mid-large diameter beveling machines.

Offering ratcheted i/d jaw locking as well as ratchet bevel feed control for effortless heavy wall preps, offered in extremely powerful user friendly servo electric or pneumatic any bevel geometry can be performed within the impressive 7" - 24" range.

J-preps, counter boring, and facing can all be performed, simultaneously, using the correct tooling fitted in (up to) 4 heavy duty hardened multi-position tool holders. Due to its light weight, yet unrivalled power, the PREP 24 is ideal for on-site, off shore, nuclear, and other applications where precision welds are required at an incredible value.

The PREP 24, like the PREP 16 utilise ratchet feed, and locking. This allows effortless setup, and enables the operator to deliver consistent feed with minimal effort.



 **MADE IN UK** 

**POWER OPTIONS:**

**SERVO ELECTRIC**

**RECOMMENDED**



**PATENT  
PENDING**

**PART NO. TP24SE110 / TP24SE220**

**PNEUMATIC**



**PART NO. TP24P**

**HYDRAULIC**



**PART NO. TP24H**

# FEATURES:

## SELF-CENTERING



Self-centering 150mm (5.9") one piece locking shaft with built in jaws, eliminates the issue of broken or loosening retaining springs and o-rings.

## UNRIVALLED POWER AND STABILITY



TAG innovative bearing/crown and pinion design combined with our large shaft, delivers unrivalled power and stability.

## SERVO ELECTRIC



**RECOMMENDED**

**PATENT  
PENDING**

SERVO ELECTRIC control box makes the strongest portable pipe beveling machine available on the market.

## EXTENSION KITS

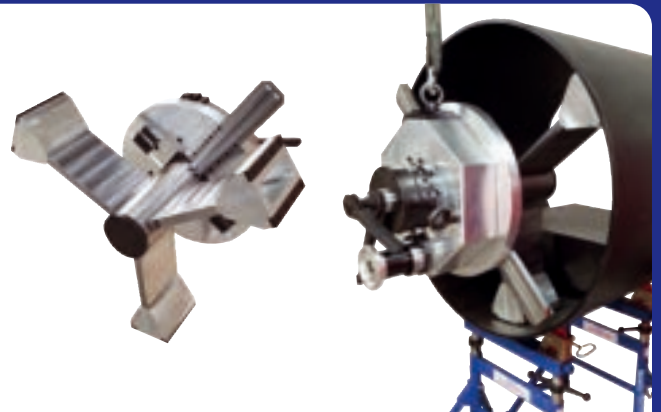

Optional extension kits up to 42" available on request.

## RATCHET FEED AND LOCKING



The PREP 24 has unrivalled power and stability, utilising a ratchet system for both jaw locking, and bevel feed.

## SIX POINT LOCKING



Innovative wide locking jaws offer 6 point locking from 3 jaws giving superior clamping force for chatter free end preps.

## PREP 24 TECHNICAL FEATURES

DESCRIPTION	MEASUREMENT	PNEUMATIC	SERVO ELECTRIC	HYDRAULIC
Part Number	n/a	TP24P	TP24SE110 / TP24SE220	TP24H
Locking tube range	mm / inch (i/d)	175 - 600mm / 6.9 - 23.6" (optional up to 42")	175 - 600mm / 6.9 - 23.6" (optional up to 42")	175 - 600mm / 6.9 - 23.6" (optional up to 42")
Working range	mm / inch (o/d)	180 - 604mm / 7 - 24" (optional up to 42")	180 - 604mm / 7 - 24" (optional up to 42")	180 - 604mm / 7 - 24" (optional up to 42")
Idle speed	rpm	2 - 9	2 - 9	2 - 14
Length of axial feed	mm / inch	60 / 2.4	60 / 2.4	60 / 2.4
Max operating temperature	°C	55	60	60
Max acoustic radiation	dB	75	45	55
Pneumatic Motor Power	hp	3.5	n/a	5.4
Air Consuming Flux	cfm / l/min.	90 / 2500	n/a	n/a
Air working pressure	psi / bar	90 / 6.5	n/a	n/a
Air Hose Connection	inches	¾"	n/a	n/a
Servo Electric Motor Power	kw	n/a	1.5	n/a
Voltage	volt	n/a	110 or 220	Refer to Hydraulic Power Pack
Frequency	Hz	n/a	50 / 60	Refer to Hydraulic Power Pack
Remote Control	Yes / No	No	Yes	Yes
Forward / Reverse	Yes / No	No	Yes	Yes
Unit weight	kg / lbs	214 / 471	216 / 476	210 / 462
Packing dimensions L x W x H	mm	1200 x 840 x 910	1200 x 840 x 910	1200 x 840 x 910
Packing weight	kg / lbs	412 / 908	424 / 935	408 / 900

*Our group policy is one of continuous improvement. Products and data tables are subject to change or vary from those illustrated.*

- All units are supplied complete with all locking jaws to cover the full range of the machine. Service tools, drawings, instruction manual and warranty certificate are also supplied as standard.
- Each machine is supplied with a protective custom built box.
- Pneumatic machine must be used with filter lubricator and oil - use without will void warranty.



### DIMENSIONS

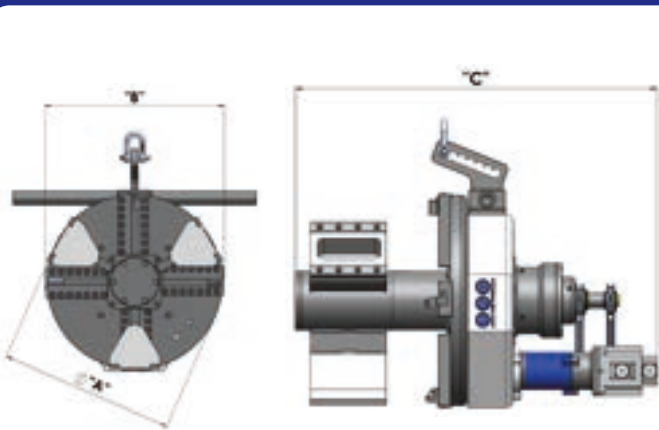

DIMENSIONS		PNEUMATIC	SERVO ELECTRIC	HYDRAULIC
∅A	mm	550	550	550
B	mm	580	580	580
C	mm	1005	955	855

### EXAMPLES OF COMMON CUTTING TOOLS

#### FORMED TOOLS

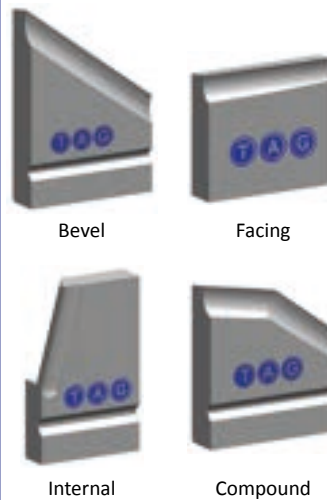

#### HOLDER / INSERT (Recommended)



All shapes, sizes and angles available



# PREP 16 AND PREP 24 ELBOW / FITTINGS

*Portable Elbow and Fitting Machine*

The TAG PREP 16 ELBOW / FITTINGS and TAG PREP 24 ELBOW / FITTINGS complete machine enables bevelling, J-preps, counter boring and facing on elbows and pipe fittings, due to its heavy duty yet compact shaft and 6 piece locking jaw system. The machines can be supplied in either servo electric, pneumatic or hydraulic.

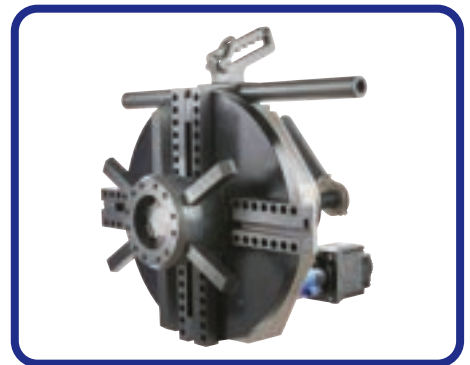

## PREP 16 AND PREP 24 ELBOW / FITTINGS TECHNICAL FEATURES

DESCRIPTION	MEASUREMENT	PNEUMATIC	SERVO ELECTRIC	HYDRAULIC
Part Number	n/a	TP16EP	TP16ESE110 / TP16ESE220	TP16EH
Locking tube range	mm / inch (i/d)	130 - 410mm / 5.11 - 16.14"	130 - 410mm / 5.11 - 16.14"	130 - 410mm / 5.11 - 16.14"
Part Number	n/a	TP24EP	TP24ESE110 / TP24ESE220	TP24EH
Locking tube range	mm / inch (i/d)	210 - 600mm / 8.26 - 23.62"	210 - 600mm / 8.26 - 23.62"	210 - 600mm / 8.26 - 23.62"

## DIMENSIONS PREP 16/24 ELBOW / FITTINGS

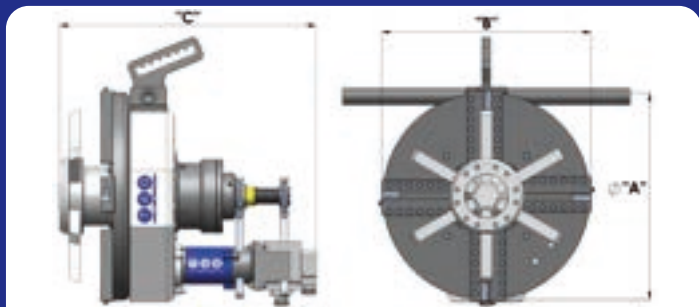

	DIMENSIONS		PNEUMATIC	SERVO ELECTRIC	HYDRAULIC
PREP 16	ØA	mm	323	323	323
	B	mm	407	407	407
	C	mm	705	650	550
PREP 24	ØA	mm	550	550	550
	B	mm	580	580	580
	C	mm	755	705	605

## EXAMPLES OF FITTINGS

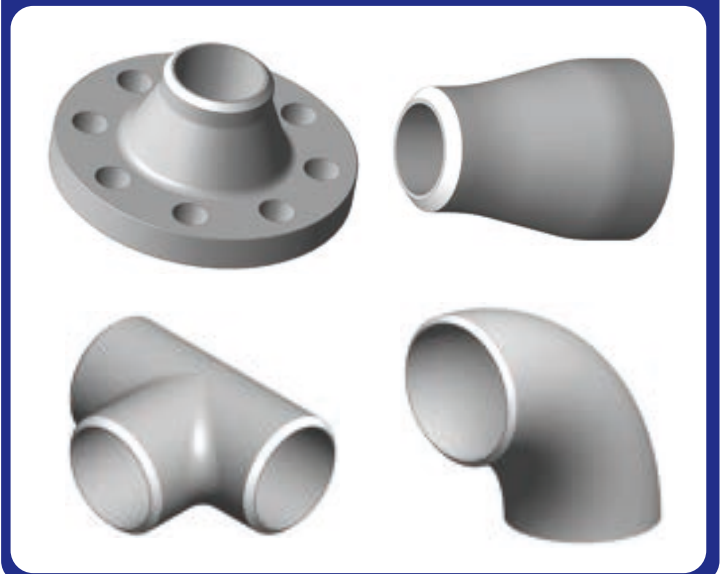



# PANEL PREP MACHINES

O/D Pipe Beveling Machine

**RANGE: 8 to 108mm (0.5 - 4")**

- **Functions:** External beveling / internal beveling / facing / counter-boring / weld removal
- **Material:** Steel, stainless steel, duplex, high alloyed

The TAG PANEL PREP attaches to the tube outside diameter by means of custom or specific o/d clamp type jaws that provide strong clamping action that minimizes chatter and vibration.

It is designed for maximum comfort, efficiency, safety, and ease of use. The feed wheel handle enables the operator to comfortably feed the tool during beveling or facing. The TAG PANEL PREP is suitable for small bore heavy wall tubes with a high percentage of chrome, stainless steel, and other exotic alloys.

The machine can be used for standard beveling applications and for opposite tubes.

MODEL	PIPE O/D RANGE	PART NO PNEUMATIC	PART NO ELECTRIC
TAG Panel Prep 2	8 - 53mm / 0.3 - 2"	TPP2P	TPP2E
TAG Panel Prep 2.5	20 - 63mm / 0.8 - 2.5"	TPP2.5P	TPP2.5E
TAG Panel Prep 3	25 - 73mm / 1 - 3"	TPP3P	TPP3E
TAG Panel Prep 3.5	30 - 83mm / 1.2 - 3.5"	TPP3.5P	TPP3.5E
TAG Panel Prep 4	50 - 108mm / 2 - 4"	TPP4P	TPP4E



Pneumatic



Electric 220 or 110v



## Clamping Jaws

MODEL	MEASUREMENT	1	2	3	4	5	6	7	8	9	10	11	12	13	14	15	16	17
TAG Panel Prep 2	O/D mm	8	10	12	14	16	18	20	22	25	28	32	38	42	44.5	48	51	53
TAG Panel Prep 2.5	O/D mm	20	22	25.4	28	32	38	42	44.5	48	51	56	57	60	63	n/a	n/a	n/a
TAG Panel Prep 3	O/D mm	25.4	28	32	38	42	44.5	48	51	57	60	63	68	70	73	n/a	n/a	n/a
TAG Panel Prep 3.5	O/D mm	25.4	28	32	38	42	44.5	48	51	57	60	63	68	70	73	76	83	n/a
TAG Panel Prep 4	O/D mm	50	54	57	60	63	68	70	73	76	83	89	95	108	n/a	n/a	n/a	n/a

One clamping jaw is only for one specific pipe size - specials can be made upon request



**PIPE EQUIPMENT SPECIALISTS**

# **SPLIT FRAME CLAMSHELL COLD CUTTING AND BEVELLING MACHINES 1" to 48"**



**SCAN QR CODE  
TO WATCH VIDEO**



# SPLIT FRAME CLAMSHELL COLD CUTTING AND BEVELLING MACHINES 1" to 48"

*Portable O/D Locking Cold Pipe Cutting and Beveling Machines*

**RANGE: 1" to 48" o/d (25 - 1,220mm)**  
*Larger sizes and customised machines available upon request*

- **Functions:** External beveling / internal beveling / counter-boring / compound bevels / J-prep beveling
- **Materials:** Any kind of steel and exotic alloy
- **Power:** Pneumatic, electric (110v or 220v), hydraulic or servo electric motor

## TSFC6 - TSFC24 (MODULAR BLOCK JAWS)



		TSFC6	TSCF8	TSCF12	TSCF16	TSCF18	TSCF20	TSCF24
Locking Range	inch o/d	1" - 6"	2" - 8"	6" - 12"	10" - 16"	12" - 18"	14" - 20"	18" - 24"
Locking Range	mm o/d	33.7 - 184	60.3 - 235	168.3 - 350	273 - 425	323.8 - 477	355.6 - 528	457.2 - 640

## TSFC30 - TSFC48 (TELESCOPIC JAWS)



		TSFC30	TSFC36	TSFC42	TSFC48
Locking Range	inch o/d	24" - 30"	30" - 36"	36" - 42"	42" - 48"
Locking Range	mm o/d	609.6 - 800	762 - 956	914.4 - 1108	1066.8 - 1280

## The basics

TAG's new range of split frame clamshells are essentially portable lathes.

Offering the versatility to cut and bevel (simultaneously if required), face, counterbore and o/d machine pipes (and vessels) of almost any diameter.

A light weight aluminium body, encases a steel inner ring gear running on solid bearings, ensuring manageability, yet extreme strength and durability.

Coupled with wide, hardened clamping feet, with easy read rule marks, enable rapid, repeatable concentric setup, even on out of round pipes and joints.

A range of tooling, power units and accessories allow you to tailor your machine to your particular job.



## Features and advantages

- 11 models cover a range from 1" (25.4 mm) to 48" (1,220 mm) o/d
- Pneumatic, hydraulic, standard electric and NC servo electric drive options provide increased versatility
- Adjustable heavy duty bearings, combined with easy access maintenance points allow inspection and adjustment
- Clamping feet are quickly and easily adjusted via a flush hex head through the outer ring. Feet feature easy read measure marks for rapid setup and adjustment
- TAG split frame clamshells accept a wide range of accessories to increase performance and expand machine capabilities
- Unique 'TAG transmission' tool slides with changeable gears for adjustable radial tool feed

## Quick split frame design

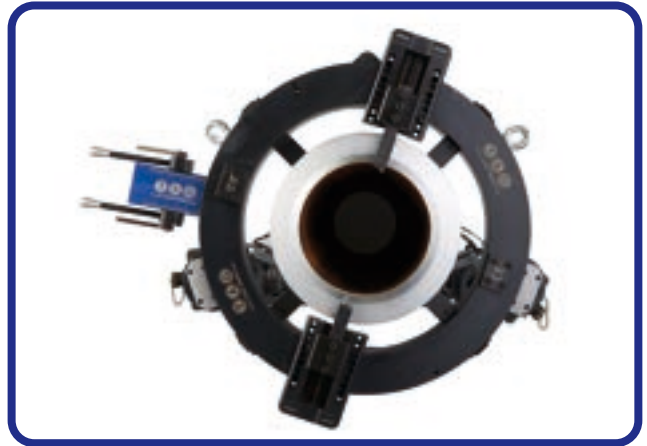

# FEATURES:



TAG advanced cam roller bearing system enables fine adjustment of bearings for optimal performance and maintenance delivering smooth precise rotation.



Using the latest high grade aluminium along with treated steel crown the TAG split frames are designed for heavy duty industrial on-site use.



Quick lock/unlock splitting hinge to enable fast setup of machine onto pipes in situ.



Custom made metal box with foam insert to insure protection of the machine.



TAG advanced feeding system delivers feed through worm and crown to evenly distribute pressure through the feeding screw, resulting in reduced vibration and wear on cutting tools.

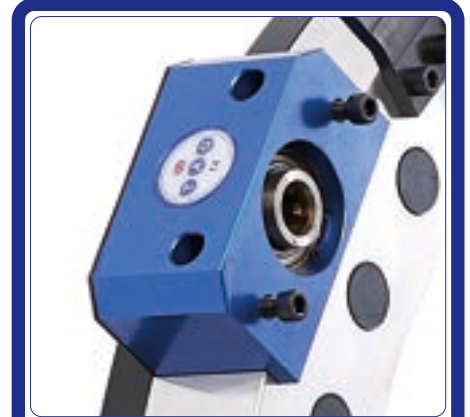

Two bolt motor mount enables fast mounting of motors. All power drives utilise the same drive block.



## MODULAR BLOCK JAWS

Modular locking system with TAG advanced external metal plate to take pressure away from aluminium ring, clamping foot size 40 x 60mm.



## TELESCOPIC JAWS

Telescopic locking system externally mounted to keep aluminium ring solid for extra strength, increased clamping foot size 55 x 115mm for fast accurate setup.



Double striker enables feeding of 0.2mm per revolution, also utilising TAG extended engaging handle meaning hands free operation.

## DRIVE UNITS

To meet the varying needs of job-sites worldwide, TAG's clamshell motors and drives are available in a range of configurations.

Drive motors are available in servo electric, hydraulic, pneumatic and electric configurations. Motor mounting flanges are available in straight back (in-line), right angle and front drive reversible options.

### TSFC6 - TSFC24

**RECOMMENDED**



Servo Electric Motor



Double Pneumatic available

Pneumatic Motor



Hydraulic Motor

**TSFC6 - TFSC12 ONLY**



Electric Motor

### TSFC30 - TSFC120

**RECOMMENDED**



Servo Electric Motor



Double Pneumatic available

Pneumatic Motor



Hydraulic Motor

## TAG'S ELECTRIC NC SERVO DRIVE MOTOR

TAG's single phase electric NC (Numerically Controlled) servo motor offers a new level of performance and capacity for electric drive power of TAG's split frame range.

A 1.5 kilowatt servo motor, which, like a 3 phase motor, or hydraulic drive, does not slow and strain under load.

The single servo motor is controlled by a wired remote.

The double servo motor, is controlled by a wireless remote or Delta touch screen NC control unit, enabling accurate, infinite RPM control.

If you carry out the same job regularly with the machine, once you find the optimum performance setting and values, these can be set into the NC control unit and recalled in the future.

Available in single for up to 30mm thickness or double for 30mm+.

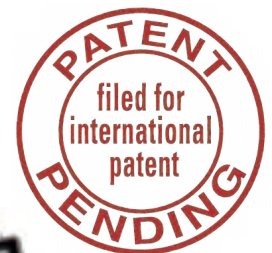

Single Servo Control



Double Servo Control

## TOOL BOXES AND ACCESSORIES

The tool slides are available in various configurations to accept the full range of TAG tooling.



### Standard Tool Box

Low profile, light weight, for tight access situations. Utilising standard TAG HSS Co blade tooling.

**For cutting and bevelling all materials up to 120mm / 4.7" wall thickness.**

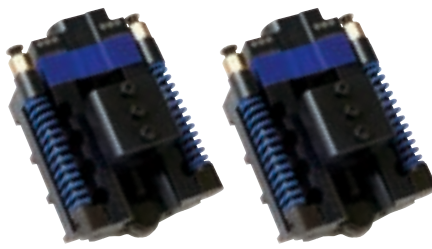

### Spring Loaded o/d Tracking

A bearing wheel housed in the tool slide, is compressed to the o/d of the pipe by 2 x 150lb springs, ensuring an even, accurate weld prep and root face, by tracking the o/d contour of the pipe especially advantageous for large diameters and out of round pipe.

**For cutting and bevelling all materials of up to 20mm / 0.8" wall thickness.**



### Counter Bore Tool Slide

The counter bore slide module accessory bolts directly to the standard tool slide and can be installed immediately upon completion of the cut and external bevel, to remove any internal inconsistencies prior to welding. The counter bore tool slide can be adjusted from 0 to 45 degree and has 150mm / 6" feed.

## TOOLING

TAG's HSS Co range of tooling includes sever/cut, bevel, double-bevel, compound bevel, J-prepping and counter bore tools. TAG tooling is available in a range of different lengths and sizes, to match tooling with application precisely.

TAG holder and insert tooling enables sever/cut, bevel, compound bevel and counter bore tools many holders utilise the same interchangeable inserts reducing the quantity of consumable parts.

We also offer custom designed tooling, special tool steel for applications not covered by our standard range.

### FIXED ANGLE BEVEL



### COMPOUND BEVEL

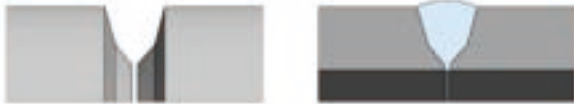

### J PREP

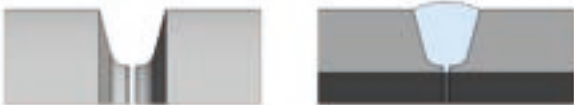

*All shapes, sizes and angles available*



## RING DIMENSIONS

		TSFC6	TSFC8	TSFC12	TSFC16	TSFC18	TSFC20	TSFC24	TSFC30	TSFC36	TSFC42	TSFC48
O/D RANGE	inch	1 - 6"	2 - 8"	6 - 12"	10 - 16"	12 - 18"	14 - 20"	18 - 24"	24"-30"	30"-36"	36"-42"	42"-48"
A	mm	184.00	235.00	350.00	425.00	477.00	528.00	640.00	800.00	956.00	1108.00	1280.00
B	mm	283.00	308.50	396.00	433.50	459.50	485.00	541.00	635.00	713.00	789.00	895.00
C MIN	mm	187.00	212.50	270.00	307.50	333.50	359.00	415.00	523.50	601.50	677.50	783.50
C MAX	mm	197.00	222.50	356.00	393.50	419.50	445.00	501.00	615.00	693.00	769.00	875.00
D	mm	340.00	391.00	506.00	581.00	633.00	684.00	796.00	1180.00	1336.00	1488.00	1800.00
E	mm	78.00	78.00	78.00	78.00	78.00	78.00	78.00	100.00	100.00	100.00	120.00
F	mm	195.50	195.50	195.50	195.50	195.50	195.50	195.50	267.50	267.50	267.50	277.50
G	mm	124.00	124.00	124.00	124.00	124.00	124.00	124.00	196.00	196.00	196.00	206.00
X	mm	130.00	130.00	210.00	210.00	210.00	210.00	210.00	255.00	255.00	255.00	265.00

Low clearance options or custom machines available on request should you have access restrictions

<b>F</b> Ring only	195.50	195.50	195.50	195.50	195.50	195.50	195.50	195.50	267.50	267.50	267.50	267.50
<b>F</b> Pneumatic Motor	535.50	535.50	535.50	535.50	535.50	535.50	535.50	535.50	727.60	727.60	727.60	727.60
<b>F</b> Servo Motor	525.50	525.50	525.50	525.50	525.50	525.50	525.50	525.50	642.50	642.50	642.50	642.50
<b>F</b> Hydraulic Motor	425.00	425.00	425.00	425.00	425.00	425.00	425.00	425.00	425.00	425.00	425.00	425.00

Right angle drive motors are available on request (extra at cost)

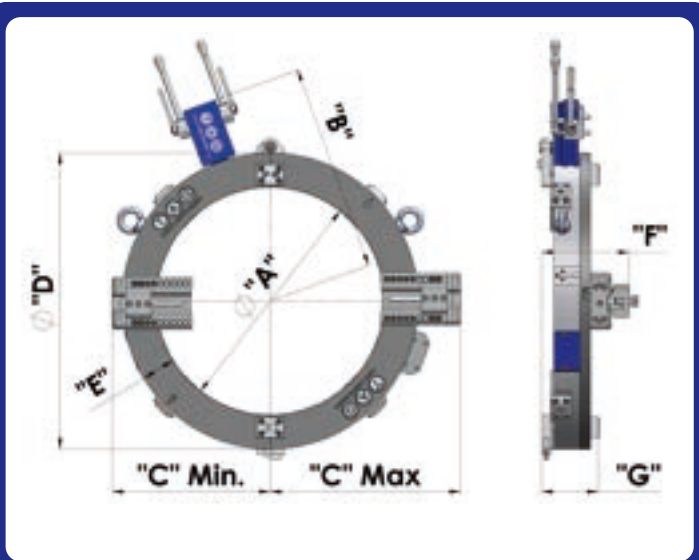

TSFC6 - TSFC24

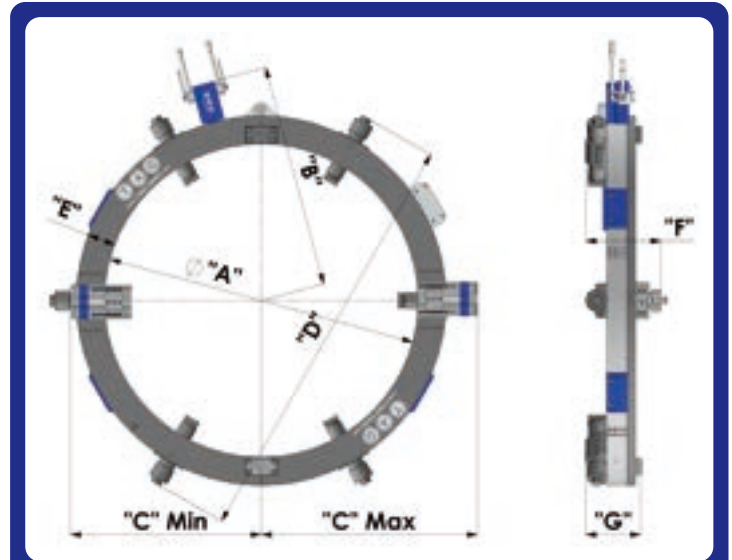

TSFC30 - TSFC48

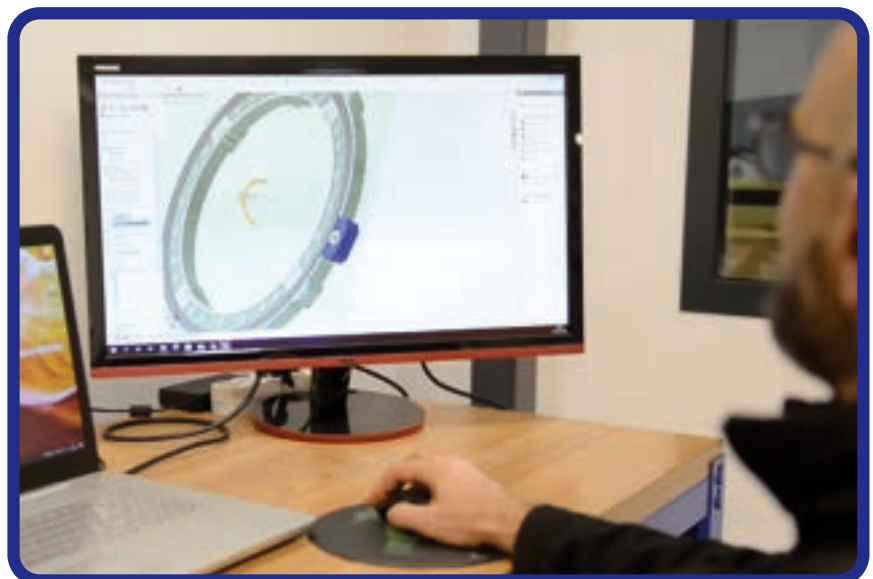
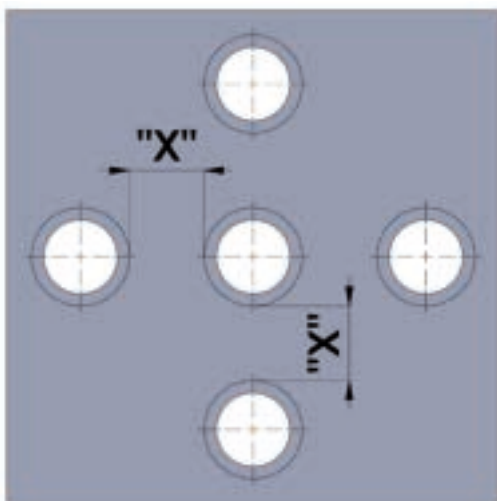

## SPLIT FRAME TECHNICAL FEATURES

		TSCF6	TSCF8	TSCF12	TSCF16	TSCF18	TSCF20	TSCF24	TSFC30	TSFC36	TSFC42	TSFC48	
Locking Range	inch o/d	1" - 6"	2" - 8"	6" - 12"	10" - 16"	12" - 18"	14" - 20"	18" - 24"	24" - 30"	30" - 36"	36" - 42"	42" - 48"	
Locking Range	mm o/d	33.7 - 184	60.3 - 235	168.3 - 350	273 - 425	323.8 - 477	355.6 - 528	457.2 - 640	609.6 - 800	762 - 956	914.4 - 1108	1066.8 - 1280	
Ring Only Weight	kg	23	32	46	53	58	62	76	183	204	242	323	
Toolbox Stroke	mm	60	60	90	90	90	90	90	90	90	90	90	
Motor Mount Positions	qty	1	1	1	2	2	2	2	2	2	4	4	
Striker Mount Positions	qty	1	1	2	3	3	3	3	3	4	4	5	
Bearing size	S/L	S	S	S	S	S	S	S	L	L	L	L	
Spline Drive Size	mm	16	16	16	16	16	16	16	25	25	25	25	
Pneumatic Idle Speed	rpm	5 - 36	5 - 28	5 - 21	5 - 18	5 - 17	5 - 16	5 - 15	1 - 8	1 - 8	1 - 7	1 - 6	
Electric Idle Speed	rpm	5 - 20	5 - 16	5 - 12	n/a	n/a	n/a	n/a	n/a	n/a	n/a	n/a	
Servo Electric Idle Speed	rpm	1 - 45	1 - 36	1 - 27	1 - 23	1 - 21	1 - 19	1 - 18	1 - 9	1 - 9	1 - 8	1 - 7	
Hydraulic Idle Speed	rpm	5 - 30	5 - 28	5 - 25	5 - 20	5 - 19	5 - 17	5 - 16	1 - 8	1 - 8	1 - 8	1 - 8	
Pneumatic Motor Power	hp	1.85	1.85	1.85	1.85	1.85	1.85	1.85	3.5	3.5	3.5	3.5	
Double Pneumatic Motor(s) Power	hp	n/a	n/a	n/a	3.7	3.7	3.7	3.7	7.0	7.0	7.0	7.0	
Electric Motor Power	watt	1900	1900	1900	n/a	n/a	n/a	n/a	n/a	n/a	n/a	n/a	
Single Servo Electric Motor Power	Kw	1.5	1.5	1.5	1.5	1.5	1.5	1.5	1.5	1.5	1.5	1.5	
Double Servo Electric Motor(s) Power	Kw	n/a	n/a	n/a	3.0	3.0	3.0	3.0	3.0	3.0	3.0	3.0	
Hydraulic Motor Power	hp	5.40	5.40	5.40	5.40	5.40	5.40	5.40	5.40	5.40	5.40	5.40	
Electric / Servo Electric Voltage	volt	110 / 220	110 / 220	110 / 220	110 / 220	110 / 220	110 / 220	110 / 220	110 / 220	110 / 220	110 / 220	110 / 220	
Electric / Servo Electric Frequency	Hz	50 / 60	50 / 60	50 / 60	50 / 60	50 / 60	50 / 60	50 / 60	50 / 60	50 / 60	50 / 60	50 / 60	
Air Working Pressure	psi / bar	90 / 6.5	90 / 6.5	90 / 6.5	90 / 6.5	90 / 6.5	90 / 6.5	90 / 6.5	90 / 6.5	90 / 6.5	90 / 6.5	90 / 6.5	
Air hose Connection	inch	¾	¾	¾	¾	¾	¾	¾	¾	¾	¾	¾	
Air Consuming Flux (Double x2)	cfm/ LPM	50 / 1400						90 / 2500					
Feed Rate per Revolution	mm / inch	0.2 / 0.008						0.2 / 0.008					
Locking System		MODULAR						TELESCOPIC					

*Our group policy is one of continuous improvement. Products and data tables are subject to change or vary from those illustrated.*

- All complete machines are supplied with: Machine ring/body, motor, tool boxes, striker, locking jaws, machine box, service tools.
- A protective custom built metal box is supplied with TSCF6 - TSCF24, all larger sizes are supplied in a custom built wooden box
- Drawings, instruction manual and warranty certificate are also supplied as standard.
- Pneumatic machine must be used with filter lubricator and oil - use without will void warranty.



## SPLIT FRAME PACKING WEIGHTS AND DIMENSIONS

SPLIT FRAME MODEL	MEASUREMENT	TSCF6	TSCF8	TSCF12	TSCF16	TSCF18	TSCF20	TSCF24	TSFC30	TSFC36	TSFC42	TSFC48	
Pneumatic	(kg/lbs)	(167/368)	(177/390)	(197/434)	(238/525)	(241/531)	(249/549)	(262/578)	(300/661)	(335/738)	(375/826)	(445/981)	
Double Pneumatic	(kg/lbs)	n/a	n/a	n/a	(258/569)	(261/575)	(269/593)	(282/622)	(320/705)	(355/782)	(395/870)	(465/1,002)	
Single Servo Electric	(kg/lbs)	(182/401)	(182/401)	(212/467)	(253/558)	(256/564)	(264/582)	(277/611)	(315/694)	(345/760)	(385/848)	(455/1,003)	
Double Servo Electric	(kg/lbs)	n/a	n/a	n/a	(283/624)	(286/631)	(289/637)	(307/677)	(345/760)	(380/837)	(420/926)	(490/1,080)	
Hydraulic	(kg/lbs)	(162/357)	(172/379)	(192/423)	(233/514)	(236/520)	(244/538)	(257/567)	(290/639)	(320/705)	(365/805)	(435/960)	
Packing Dimensions	L x W x H mm	1,200 x 900 x 470			1,450 x 1,000 x 510				1,460 x 1,460 x 500		1,600 x 1,600 x 500		1,960 x 1,960 x 500

# TAG SPLIT FRAME UK PRODUCTION

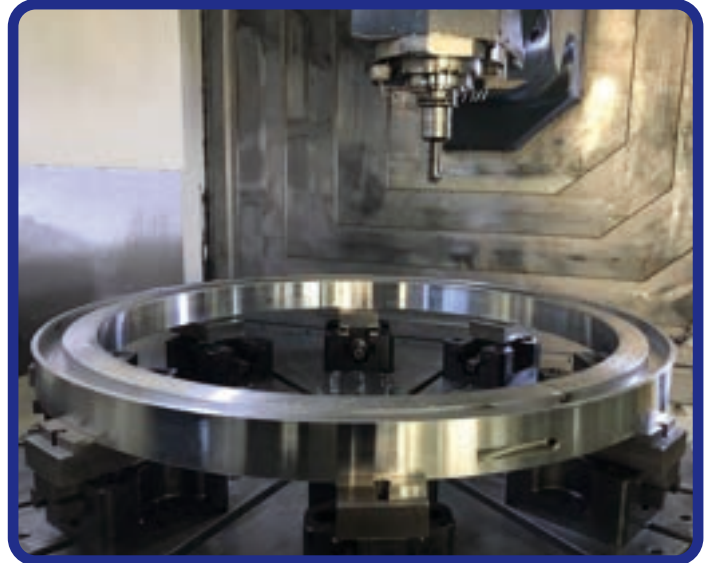
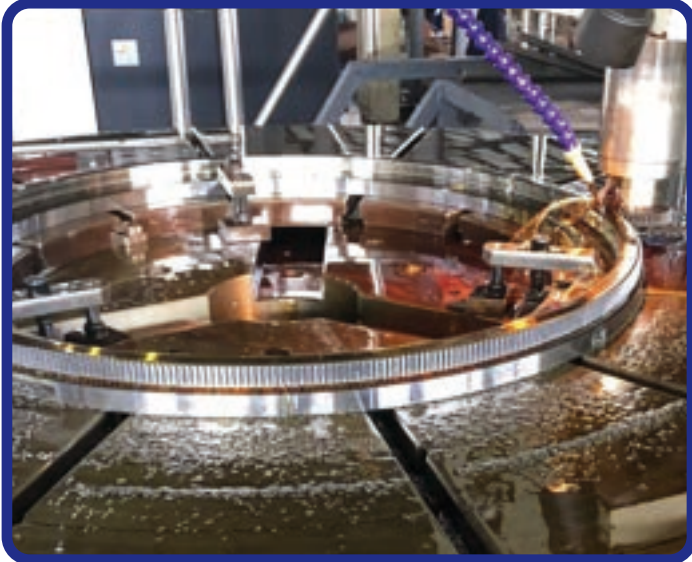

**MADE IN UK**





# EXAMPLES OF JOBS DONE WITH TAG SPLIT FRAME CLAMSHELLS

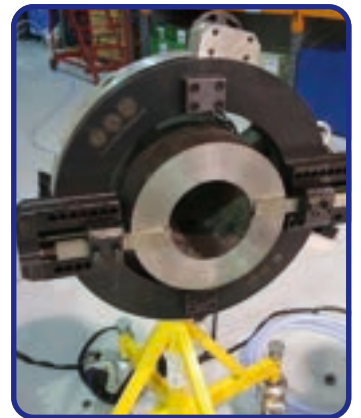
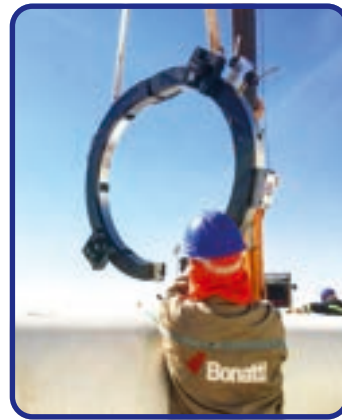



PIPE EQUIPMENT SPECIALISTS

# SPLIT FRAME CLAMSHELL COLD CUTTING AND BEVELLING MACHINES 48" to 120"



SCAN QR CODE  
TO WATCH VIDEO



Heavy Duty Steel Body

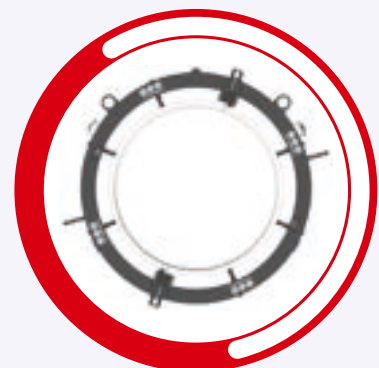

## The Basics

TAG's new range of split frame clamshells are essentially portable lathes.

Offering the versatility to cut and bevel (simultaneously if required), face, counterbore and O/D machine pipes (and vessels) of almost any diameter.

A steel body encases a steel inner ring gear, running on solid bearings.

Coupled with wide, hardened clamping feet, with easy read rule marks, enable rapid, repeatable concentric setup, even on out of round pipes and joints.

A range of tooling, power units and accessories allow you to tailor your machine to your particular job.

## Features and Advantages

- 5 models cover a range from 48" (1,220 mm) to 120" (3,050 mm) O/D
- Pneumatic, hydraulic and NC servo electric drive options provide increased versatility
- Adjustable heavy duty bearings, combined with easy access maintenance points allow inspection and adjustment
- Clamping feet are quickly and easily adjusted via a flush Hex head through the outer ring. Feet feature easy read measure marks for rapid setup and adjustment
- TAG split frame clamshells accept a wide range of accessories to increase performance and expand machine capabilities
- Unique 'TAG transmission' tool slides with changeable gears for adjustable Radial tool feed

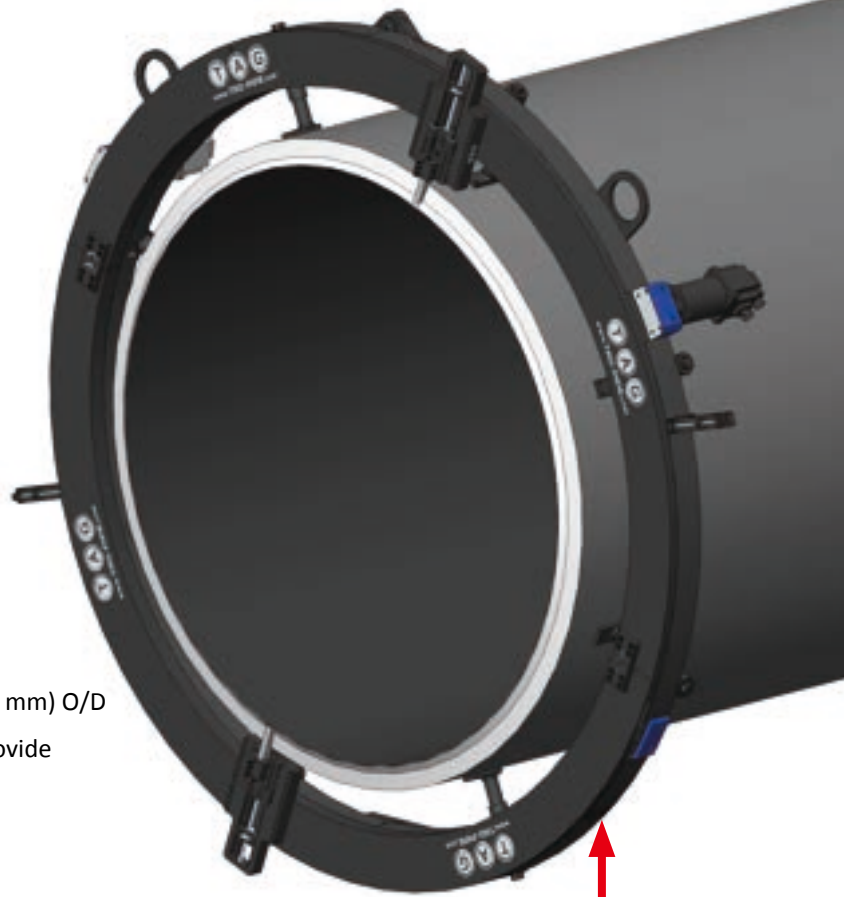

**Heavy Duty Steel Body**

MODEL	RANGE O/D (INCH)	RANGE O/D (MM)	CLAMPING JAWS
TSFC60	48 - 60"	1,220 - 1,524mm	8
TSFC75	60 - 75"	1,524 - 1,910mm	8
TSFC90	75 - 90"	1,910 - 2,290mm	12
TSFC105	90 - 105"	2,290 - 2,680mm	12
TSFC120	105 - 120"	2,680 - 3,050mm	12

Larger sizes available upon request





**PIPE EQUIPMENT SPECIALISTS**

# TAG E-Z FAB PIPE CUTTING AND BEVELLING MACHINE 1" to 24"

SCAN QR CODE  
TO WATCH VIDEO

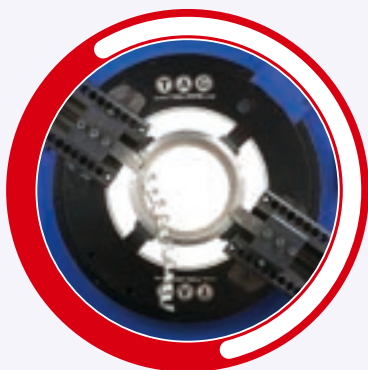



# E-Z FAB PIPE COLD CUTTING AND BEVELLING MACHINE

*O/D Locking Cold Pipe Cutting and Beveling Machines*

**RANGE: 1 to 24" o/d (30 - 620mm)**

- High speed process pipe cutting and bevelling
- UNIQUE touch screen NC servo electric drive
- Combines accuracy with safety
- Several automation modes
- Any material
- Customisable to your needs



The E-Z FAB is a revolutionary new cutting and bevelling system for pipes. Ideally suited, but not limited to workshops, and high productivity process environments.

The E-Z FAB utilises a similar principle to our clamshell split frame cutting and bevelling machines.

However, the rotating, working inner ring is 1 piece, and is housed in a cast outer body, meaning strength, rigidity and speed. Due to its stability and powerful 1.5kw servo electric motor. The ring is 1 piece meaning that it can rotate at high speed, whilst maintaining a stable, precise cut.

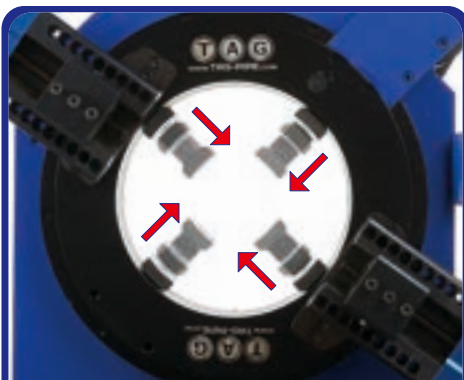

Self centering locking system for rapid alignment and clamping of pipe



Built in coolant pump unit with drip tray as standard



Sealed electrical box housing all NC controls and cabling

*All shapes, sizes and angles available*



Range of formed cutting tools available for cutting all thickness's of pipe and bevelling at any required angle

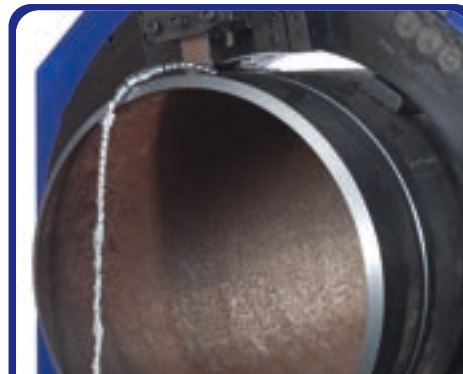

Pipe cutting



Pipe bevelling



# E-Z FAB PIPE COLD CUTTING AND BEVELLING MACHINE

## Touch screen

The E-Z FAB has been fitted with a powerful 1.5KW Delta servo motor with Delta NC control. This enables ease of use with all functions touch screen, we have used our 25 years experience to recommend pre-set speeds for pipe size/material as you can see below this enables very quick and easy set up with no human error.

The numerically controlled (NC) servo motor offers unrivalled power and cut speeds, from a touch screen Delta control system, conveniently mounted on an adjustable stalk-arm for operating ease.

The touch screen control comes with 2 main settings: manual and automatic.

The automatic option offers pre-set cut rotation speeds for pipes within each machines' range, whilst the manual option allows the operator to adjust the speed of the machine themselves.

\* Touch screen controls can be customised during commissioning/training.

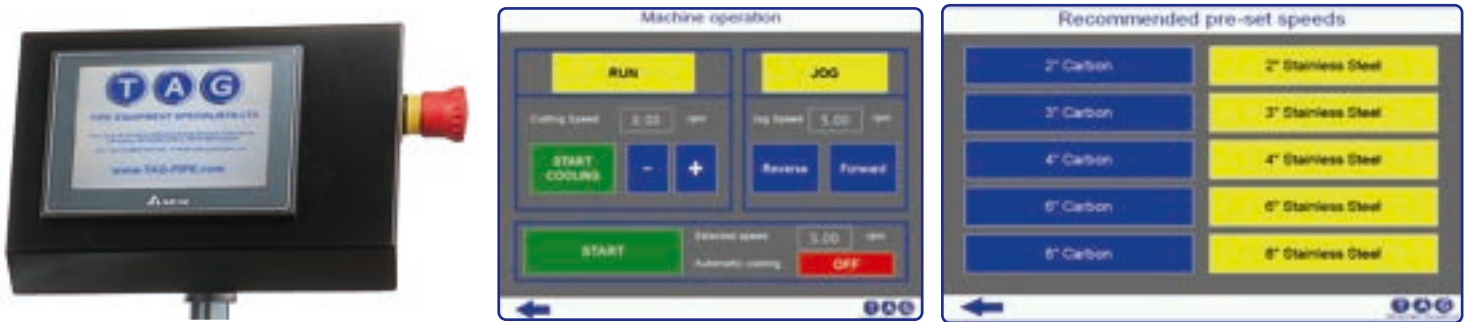

## Models available

MODEL	RANGE O/D (INCH)	RANGE O/D (MM)	WALL THICKNESS (MM)
EZFAB6	1 - 6"	30 - 170mm	6 - 40mm
EZFAB8	2 - 8"	70 - 220mm	6 - 40mm
EZFAB12	6 - 12"	170 - 320mm	6 - 40mm
EZFAB16	10 - 16"	270 - 420mm	6 - 40mm
EZFAB20	14 - 20"	370 - 520mm	6 - 40mm
EZFAB24	18 - 24"	470 - 620mm	6 - 40mm

\* Wall thickness' less than or greater than the above can be achieved with accessories - please contact TAG.

## Example cutting and bevelling times

PIPE SIZE	PIPE SHD	WALL THICKNESS (MM)	PIPE MATERIAL	PRE-SET SPEED	CUTTING AND BEVELLING TIME
2 inch	SHD40	4mm	Stainless Steel	45rpm	2 minutes
4 inch	SHD40	4mm	Stainless Steel	30rpm	2.5 minutes
6 inch	SHDXXS	22mm	Carbon	35rpm	5 minutes
8 inch	SHD40	8mm	Stainless Steel	20rpm	9 minutes

## Centreline of cutting point

MODEL	(A) MM	(A) INCH
EZFAB6	1,187.50	46.75
EZFAB8	1,196.00	47.08
EZFAB12	1,132.50	44.58
EZFAB16	1,177.50	46.35
EZFAB20	1,137.50	44.78
EZFAB24	1,462.50	57.57

\* Minus 155mm / 6.10" without castor wheels

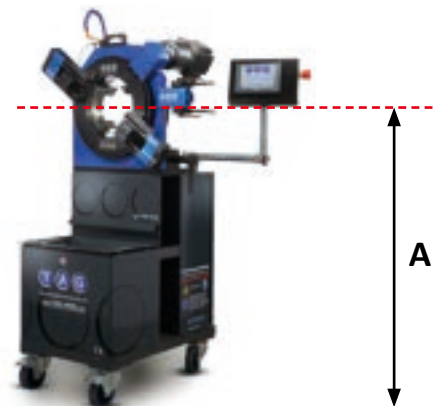

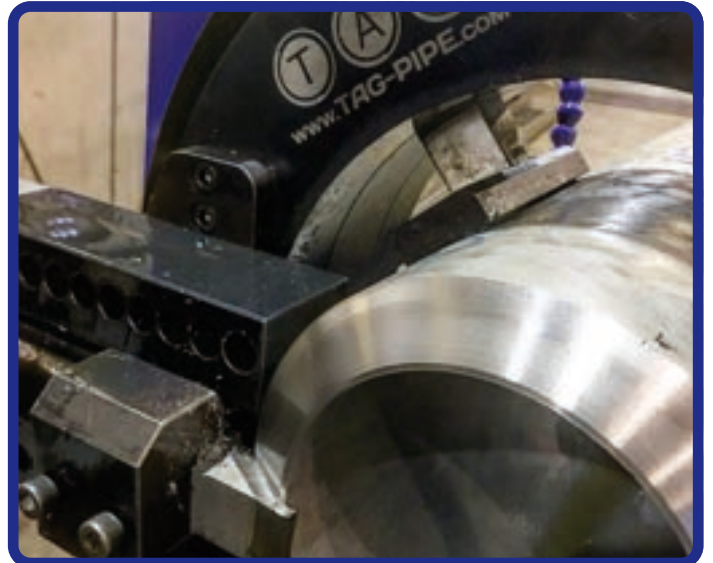
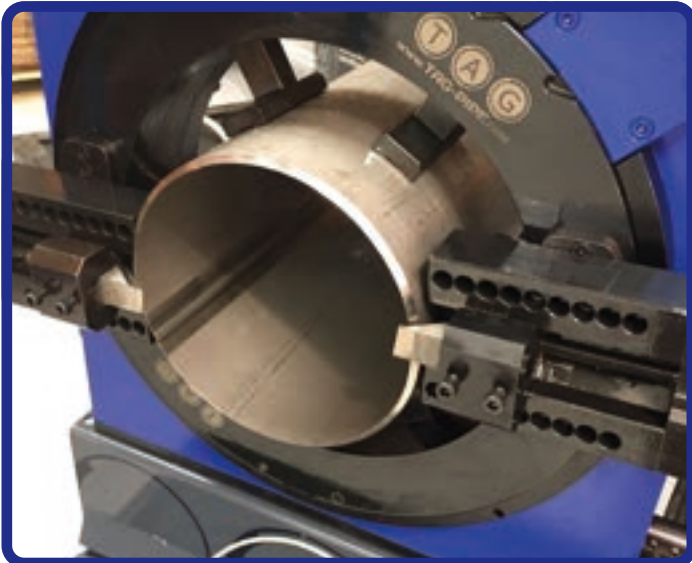
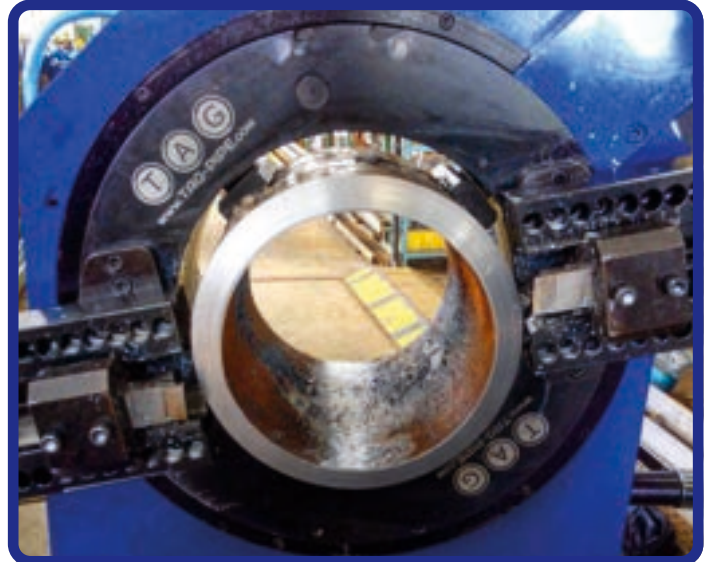

**MADE IN UK**



**RANGE: 1 - 12" (optional up to 24")**

- **Function:** Cutting up to 45° inclination
- **Material:** Any kind of steel
- **Power:** Pneumatic or electric

The light weight construction and ease of set up and operation makes it ideal for site work applications. It is capable of cutting most materials including stainless steel.



Electric



Pipe locking vice for 1" to 6". Adjustable blade position to cut angles from 90° to 45°. Stop feeding stroke included in the standard equipment.



Chain vice for 4" to 12". Stop feeding stroke included in the standard equipment.



Pneumatic

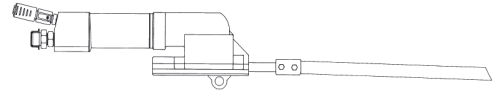

660 x 209 x 98mm

## TECHNICAL SPECIFICATION

Description		E-Z Pipe Saw Pneumatic	E-Z Pipe Saw Electric
Part Number		EZSP	EZPSE100 / EZPSE220
Locking tube range	mm	25 - 323 o/d	25 - 323 o/d
Recommended working range	inch o/d	1 - 12"	1 - 12"
Torque	N m	186	265
Max operating temperature	°C	55	55
Max noise level	dB	75	75
Pneumatic motor power	hp	1.33	-
Air consumption	cfm	55 - 60	-
Air working pressure	psi	90	-
Air hose connection	inch	¾"	-
Electric motor power	watt	-	1400 (adj)
Voltage	volt	-	110 / 220
Frequency	Hz	-	50
Idle Speed	strokes/min	300	450
Unit weight	kg / lbs	11 / 24	9 / 20
Packing dimensions	L x W x H mm	640 x 280 x 130	640 x 280 x 130
Packing weight	kg / lbs	16 / 35	14 / 31



PIPE EQUIPMENT SPECIALISTS

## PLATE BEVELLING MACHINES



**RANGE: Thickness 1.5mm upwards / Bevel Angle: from 20° to 60°**  
**Max Bevel Width: 16mm / Max Radius: 5mm**

- **Materials:** Any kind of steel, aluminium, brass or plastics
- **Power:** 110 or 220v or pneumatic

For the deburring of outer and inner outlines, beveling, milling of radii and bore holes as from 20mm  $\varnothing$ .

Especially developed to produce clean visible edges and to prepare welds.

- Tool-less adjustment of bevel height
- Handy and powerful
- For construction steels, stainless steels, aluminium and other materials
- Multiple indexable insert holder 45° (optional 30°)
- Also for radii R = 2.5

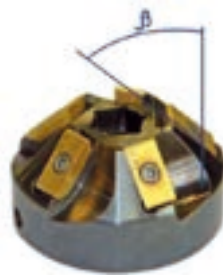
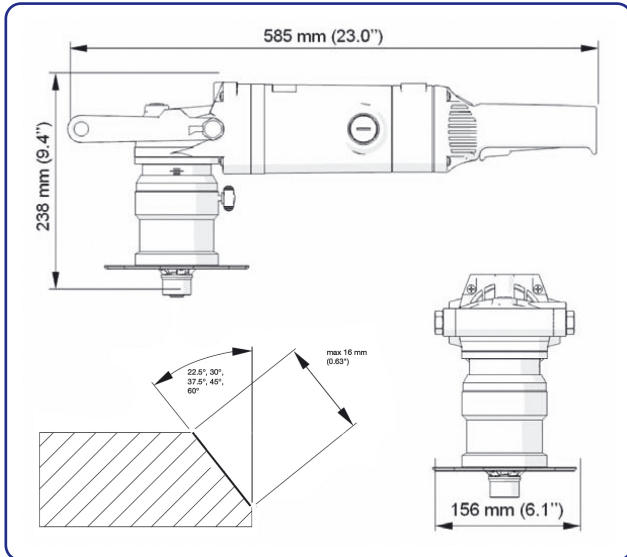

Bevel milling head

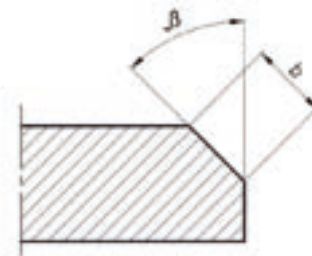

Radius milling head

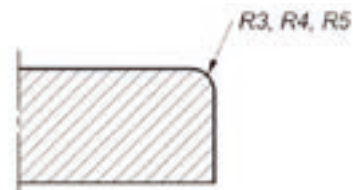

#### TECHNICAL SPECIFICATION

Power Supply	230v / 110v 50 - 60 Hz
Motor	2200W
Motor speed	1800 - 5850rpm
Minimal diameter of countersinking	40mm
Beveling with radius	R3, R4, R5
Maximal bevel width	@ 45° (b) 16mm
Feed	0,5 - 10 m/min (manual)
Beveling angles	20°, 22.5°, 30°, 37.5°, 45°, 50°, 55° and 60° (other angles upon request)
Plate thickness	Minimum 1.5mm
Dimensions	585 x 156 x 238mm
Weight	10kg / 22lbs

**RANGE: Thickness 6 to 60mm / Bevel Angle: from 0° to 60° / Max Bevel Width 21mm**

- **Materials:** Any kind of steel and aluminium
- **Power:** 110 or 220v

The PMM200 - is a new generation, easy to use, portable, heavy duty machine designed for beveling steel plates prior to welding. This beveling machine is fitted with a mono block milling head containing 10, offset inserts, allowing smooth operation and exceptional efficiency. One set of inserts can last for up to 2000 meters of bevelled steel edge and allows to work with an output around 1.5 meters/minute (depending on the amount of the metal being removed).

The PMM200 incorporates many safety features. It has a state of the art electronic control module protecting the operator, machine and tools. It is equipped with guide rolls, which make it easy and light to operate.

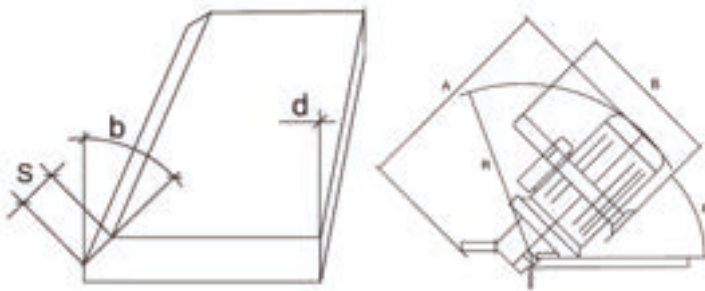

A mm (")	B mm (")	R mm (")	S mm (")	D min mm (")	a (°)	b (°)	g (°)	d = 0°	Weight kg (lbs)
420 16 5/8	330 13	305 12	0-20 0-3/4	150 6	45-75	15-60	75-30	Yes	20.0 43



Pipe beveling possible with no accessories up to 12".  
An optional attachment for beveling up to 24" is also available.



Mono block milling head, with 10 indexable inserts fixed with screws.



Continuous angle adjustment from 0 to 60 degrees.



Plate facing-off



Plate beveling

#### TECHNICAL SPECIFICATION

Power Supply	1,1 KW, 110v or 230v
Motor	Inductive with increased start-up current
Motor speed	2.820 rpm
Tooling	Integral milling head with 10 square inserts
Standard angles range	0° - 60°
Optional functions	Plate facing
Plate Thickness	Minimum 6 mm
Dimensions	480 x 420 x 360 mm
Weight	20kg / 44lbs

**RANGE: Thickness 6 to 60mm / Bevel Angle: from 0° to 60° / Max Bevel Width 21mm**

- **Materials:** Any kind of stainless steel. Will prep all other steels also.
- **Power:** Electric 110 or 220v

The PMM200SS is designed to work on stainless steel with its new powerful slow speed motor, The PMM200SS also has guide plate with guide rolls made of stainless steel, The PMM200SS is easy to use, portable, heavy duty machine designed for beveling steel/ stainless steel plates prior to welding.

This beveling machine features a new single milling head equipped with 10 square, indexable inserts makes machining process far more efficient and much less operator fatiguing smooth operation and exceptional efficiency. Capable of beveling around 1.5 meters/minute (depending on the amount of the metal being removed).

The PMM200SS incorporates many safety features. It has a state of the art electronic control module protecting the operator, machine and tools. It is equipped with guide rolls, which make it easy and light to operate. Vibration insulation protects both the operator and electronics against vibration.

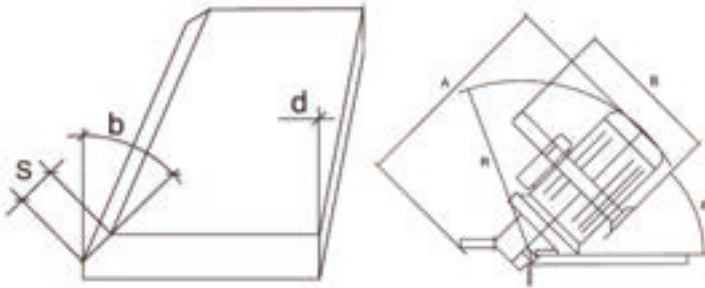

A mm (")	B mm (")	R mm (")	S mm (")	D min mm (")	a (°)	b (°)	g (°)	d = 0°	Weight kg (lbs)
420 16 5/8	330 13	305 12	0-20 0-3/4	150 6	45-75	15-60	75-30	Yes	20.0 43



Pipe beveling possible with no accessories up to 12".  
An optional attachment for beveling up to 24" is also available.



Mono block milling head, with 10 indexable inserts fixed with screws.



Continuous angle adjustment from 0 to 60 degrees.



Plate facing-off



Plate beveling

#### TECHNICAL SPECIFICATION

Power Supply	1,1 KW, 110v or 230v
Motor	Inductive with increased start-up current
Motor speed	2.820 rpm
Tooling	Integral milling head with 10 square inserts
Standard angles range	0° - 60°
Optional functions	Plate facing
Plate Thickness	Minimum 6 mm
Dimensions	480 x 420 x 360 mm
Weight	20kg / 44lbs

# NOTES

A series of horizontal dotted lines for taking notes.



SPECIALIZED FABRICATION EQUIPMENT GROUP

## Global Locations:



## United States:

### SFE HOUSTON

SPECIALIZED FABRICATION EQUIPMENT GROUP

4433 South Dr, Houston,  
Texas 77053, USA

Tel: +1 713 747 8502

E-mail: sales@sfe-brands.com

### SFE TULSA

SPECIALIZED FABRICATION EQUIPMENT GROUP

7136 South Yale Ave, Tulsa,  
Oklahoma 74136, USA

Tel: +1 713 747 8502

E-mail: sales@sfe-brands.com

## International:

### SFE UNITED KINGDOM

SPECIALIZED FABRICATION EQUIPMENT GROUP

Unit 15 & 16 Grendon Industrial Estate,  
Grendon Underwood, Aylesbury,  
Buckinghamshire, HP18 0QX England

Tel: +44 (0)1869 324 144

E-mail: sales-int@sfe-brands.com

### SFE BELGIUM

SPECIALIZED FABRICATION EQUIPMENT GROUP

Mosten 13, 9160 Lokeren  
Belgium

Tel: +44 (0)7741 551536

E-mail: sales-belgium@sfe-brands.com

### SFE FRANCE

SPECIALIZED FABRICATION EQUIPMENT GROUP

Acces bureau, 34 Rue du Docteur Abel,  
26000 VALENCE, France

Tel: +44 (0)7741 872489

E-mail: sales-france@sfe-brands.com

### SFE GERMANY

SPECIALIZED FABRICATION EQUIPMENT GROUP

Am Güterbahnhof 1, 77694 Kehl am Rhein,  
Germany

Tel: +49 (0)7851 9553507

Mob: +44 (0)7741 872489

E-mail: sales-germany@sfe-brands.com

### SFE MIDDLE EAST

SPECIALIZED FABRICATION EQUIPMENT GROUP

Al Ittihad Street, P.O. Box 3763  
Dubai, United Arab Emirates

Tel: +971 (0)50 217 1376

E-mail: sales-me@sfe-brands.com

### SFE INDIA

SPECIALIZED FABRICATION EQUIPMENT GROUP

Plot No. PAP 3, D 3 Block,  
Chinchwad, Pune 411 019

Mob: +91 90 1102 4332

Mob: +91 95 5258 4361

E-mail: sales-india@sfe-brands.com

### SFE ASIA

SPECIALIZED FABRICATION EQUIPMENT GROUP

Emerald Block A, No.2, Road N4, Son Ky Ward,  
Tan Phu District, Ho Chi Minh, Vietnam.

Tel: 0919.517.01

E-mail: sales-asia@sfe-brands.com

Copyright © 2021 Specialized Fabrication Equipment Group, All rights reserved. TAG\_CompleteMachinesBrochure2021\_English

## OUR BRANDS



PIPE EQUIPMENT SPECIALISTS



By Mathey Dearman